



SCIENCE SAMPLE PAPER

General information

1. You do **not** need to answer in full sentences.
2. You can write in pencil or pen.
3. If you are unsure about a question, read it again carefully and look for clues in the question. If you are still unsure, move on to the next question and come back to this one at the end.
4. Please do not worry if you have not covered some of the topics and skills in your current school – this lets us see which areas you might need a bit of help with at the start of Year 8.

Entry to Year 8

Q1. Jay collected pond snails from the school pond. He measured the lengths of all their shells.

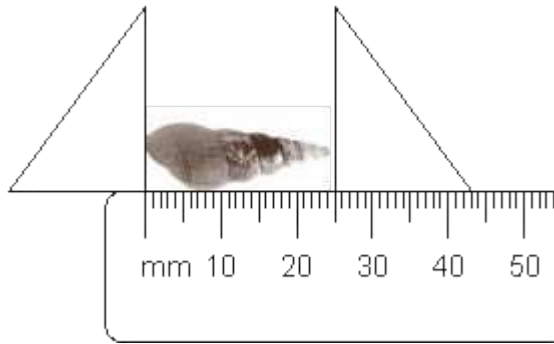

(a) What is the length of the shell above?

..... mm

1 mark

(b) Jay made a tally chart of the lengths of all the shells he found.

range of lengths of shells (mm)	0-5	6-10	11-15	16-20	21-25	26-30
number of shells	I	I	I	III	IIII	I

What was the most common **range** of lengths of shells Jay collected?

..... mm

1 mark

(c) Jay recorded his results in a bar chart.

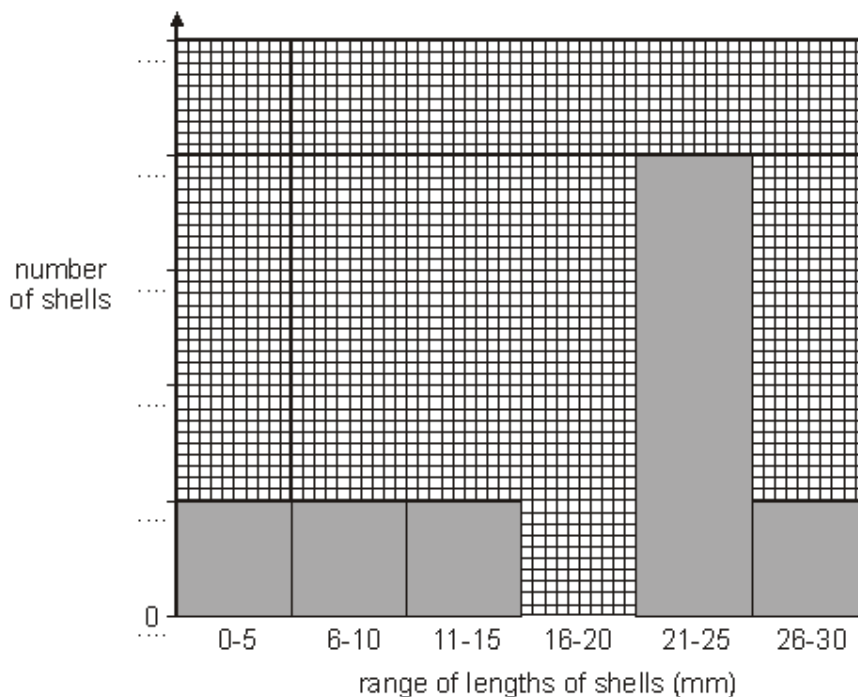

- (i) Add the missing numbers to the side of the bar chart labelled 'number of shells'. 1 mark
- (ii) **On the chart on the previous page**, draw the bar for the number of shells measuring 16-20 mm. 1 mark

- (d) Look at Jay's results and decide if each conclusion below is **true** or **false** or if you **cannot tell**.
Tick the correct box for each conclusion.

conclusions	true	false	cannot tell
The oldest snails have the darkest shells.	<input type="checkbox"/>	<input type="checkbox"/>	<input type="checkbox"/>
He did not find any shells longer than 30 mm.	<input type="checkbox"/>	<input type="checkbox"/>	<input type="checkbox"/>
He found a total of eight snails.	<input type="checkbox"/>	<input type="checkbox"/>	<input type="checkbox"/>
All the snails he found are the same type.	<input type="checkbox"/>	<input type="checkbox"/>	<input type="checkbox"/>

2 marks

- Q2.** The drawing shows a toy shark. Magnets X and Y make the shark 'float' above the plastic base.

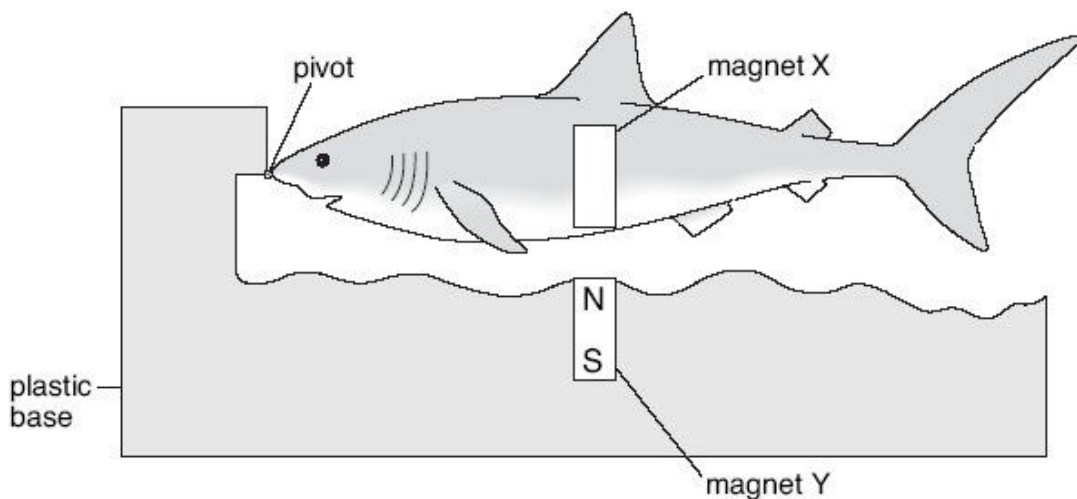

- (a) On magnet X, write the letters N and S to label the poles of the magnet. 1 mark
- (b) (i) Choose a word from the list below to complete the sentence.

attract cancel repel

The toy shark 'floats' because the magnets each other.

1 mark

(ii) Sophie pressed down on the tail of the shark with her finger.

What happened to the shark when she removed her finger?

..... 1 mark

(c) Sophie added weights to the toy shark and measured the distance between the two magnets.
Her results are shown below.

weight added to the toy shark (N)	distance between the magnets (mm)
0.1	6
0.2	4
0.3	3

Complete the sentence below.

As the weight on the toy shark increased, the distance between the magnets

.....

1 mark

(d) Sophie turned the magnet in the plastic base the other way up.

What happened to the shark?

.....

1 mark

Q3. Joanne burnt four different crisps.
She predicted that the bigger the crisp, the longer it will burn.

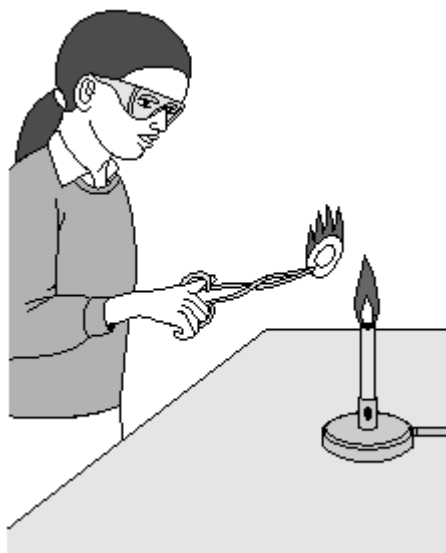

(a) Look at the picture above. What did Joanne wear to protect herself?

.....

1 mark

- (b) Joanne measured the time taken for each crisp to burn completely. The bar chart shows Joanne's results.

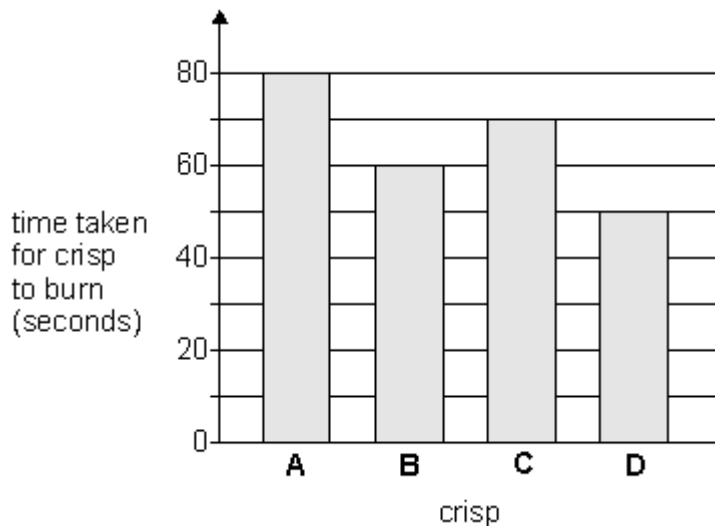

Look at the bar chart.
How much time did crisp D take to burn?

..... seconds

1 mark

- (c) The crisps Joanne used in her investigation are shown below.

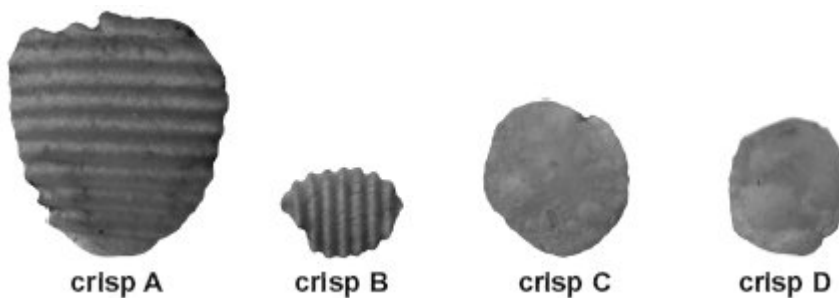

- (i) Joanne predicted that the bigger the crisp, the longer it will burn. Do the results support Joanne's prediction? Tick one box.

yes no

Use Joanne's results to explain your answer.

.....
.....

1 mark

- (ii) How can you tell that Joanne did **not** carry out a fair test?

.....

1 mark

- (d) Joanne wrote some conclusions for her investigation. Decide whether each conclusion is **true**, **false**, or you **cannot tell**. Tick the correct box for each conclusion.

conclusion	true	false	cannot tell
Two crisps took the same amount of time to burn.	<input type="checkbox"/>	<input type="checkbox"/>	<input type="checkbox"/>
The smallest crisp burnt for the shortest time.	<input type="checkbox"/>	<input type="checkbox"/>	<input type="checkbox"/>
Two of the crisps burnt with flames of the same size.	<input type="checkbox"/>	<input type="checkbox"/>	<input type="checkbox"/>

3 marks

Q4. Jack and Aneesa dropped a steel ball into trays of damp sand. They measured the depth of the craters made by the steel ball.

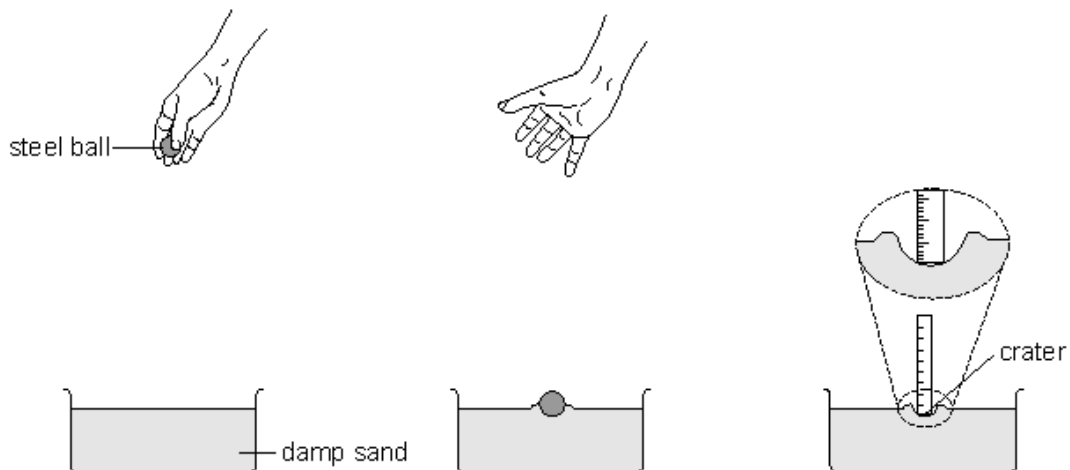

Their results are shown in the table below.

height the ball was dropped from (cm)	depth of crater (cm)		
	Jack's results		Aneesa's results
10	1.1	1.2	0.8
20	1.4	1.5	1.4
30	1.6	1.6	1.5
40	1.8	1.7	1.8
50	2.0	2.1	2.1

(a) Use information in the table to answer the questions below.

(i) What was the independent variable that Jack and Aneesa changed in their investigation?

..... 1 mark

(ii) Why was Jack's investigation better than Aneesa's?

..... 1 mark

(b) Look at the results in the table.

What is the relationship between the height the ball was dropped from and the depth of the crater?

.....
..... 1 mark

(c) Aneesa said that they made sure the investigation was fair.

Suggest **two** variables they must have kept the same to make their investigation fair.

1
2 2 marks

(d) (i) Jack removed the steel ball using his fingers. Then he measured the depth of the crater.
Aneesa said he should use a magnet instead of his fingers.

Explain why using a magnet to remove the ball would improve the investigation.

.....
..... 1 mark

(ii) Jack said that the ball could be dropped using an electromagnet instead of dropping it by hand.

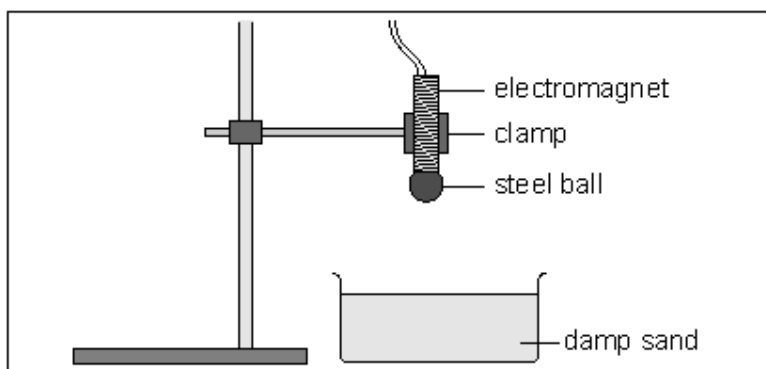

Explain why this would improve the investigation.

.....

1 mark

Q5. Mushui and Sara investigated how pupils in their class were the same and different.

First they measured the length of each pupil's little finger.

(a) Why should each pupil keep their little finger straight while it was being measured?

.....

1 mark

(b) The bar chart shows their results.

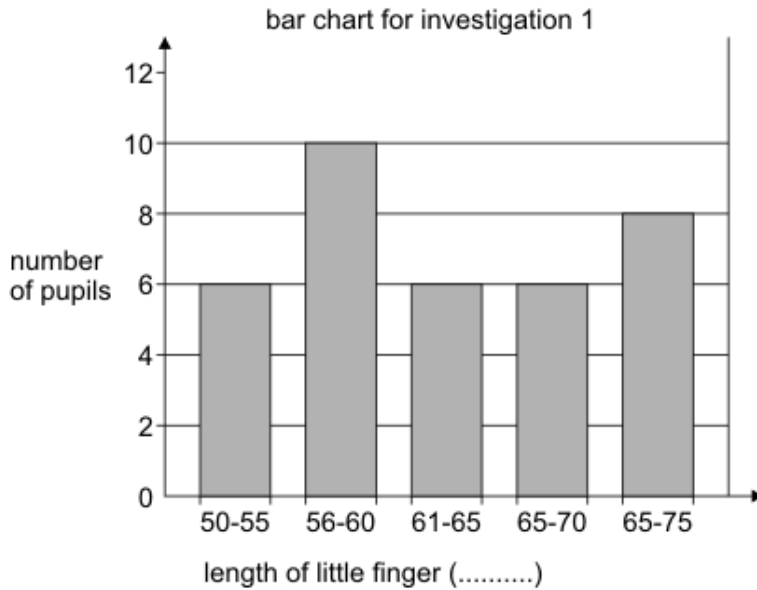

(i) **On the dotted line** under the bar chart, give the units of measurement they used.

1 mark

(ii) Give **one** mistake they made in the way they grouped the finger lengths in their bar chart.

.....

1 mark

(c) Mushui and Sara then counted the number of pupils who can and **cannot** roll their tongues. What method did they use to collect their data? Tick the correct box.

Observe pupil's tongues.

Look at books.

Identify factors to keep the same.

Measure pupil's tongues.

1 mark

(d) They recorded their results in a table.

results for investigation 2

can roll tongue	cannot roll tongue
10	4

Draw a bar on the chart below to show how many pupils can roll their tongues.

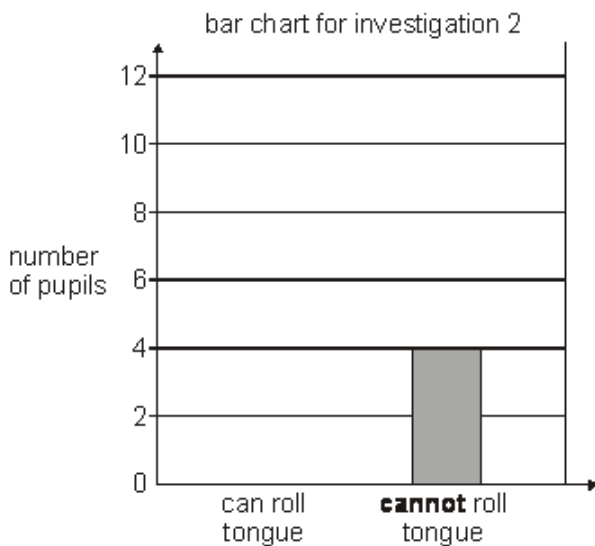

1 mark

(e) Look at their **bar charts** for investigations 1 and 2. How can you tell that they used different numbers of pupils in each investigation?

.....

1 mark

Q6. Kiran lit a candle. She placed a 100 cm³ glass jar over the candle. The candle flame went out after 2 seconds.

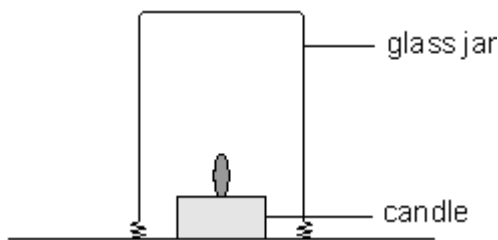

(a) Why did the flame go out?

.....

1 mark

- (b) Kiran put different sized jars over a lit candle. She measured the time it took for the flame to go out each time. She recorded her results in a table.

size of jar (cm ³)	time for candle to go out (s)
100	2
250	5
500	9
1000	22
2000	37
3000	60

- (i) **Plot Kiran's results** on the graph paper below. The first one has been done for you.

1 mark

- (ii) Draw a line of best fit.

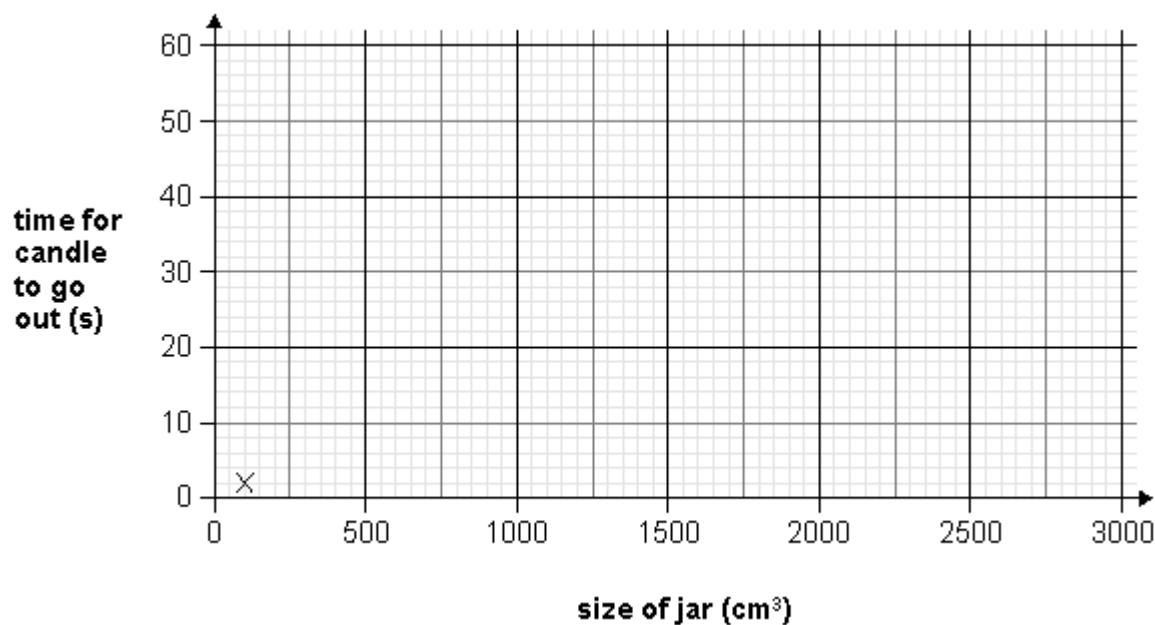

1 mark

- (iii) What conclusion can you make from her results?

.....

1 mark

(c) What should Kiran keep the same in this experiment to make it a fair test?

.....

1 mark

(d) Suggest **one** way for Kiran to make her results more reliable.

.....

1 mark

Mark schemes

Q1.

- (a) • 25

accept '2.5 cm'

1 (L3)

- (b) • 21–25

accept 2.1 cm–2.5 cm

1 (L3)

- (c) (i) • numbers from 1 to 5 written on the y-axis
accept numbers from 1 to 4 written on the y-axis

1 (L4)

- (ii) • bar drawn in the chart to 3
*give credit for a correctly drawn bar to 3 squares when the axis is **not** labelled **or** is labelled incorrectly*
give credit for a bar drawn consistent with the labelling on the axis

1 (L4)

- (d) • true false cannot tell

		✓
✓		
	✓	
		✓

if all four rows are correct, award two marks if three rows are correct, award one mark if more than one box is ticked in any row, award no credit for that row

2 (L3)

Q2.

- (a)



***both** poles are required for the mark S*

1 (L4)

- (b) (i) repel

1 (L4)

- (ii) it moved upwards **or** returned to its original position
accept 'it would move up and down'

[6]

1 (L4)

- (c) decreased
accept 'got smaller'; accept 'moved closer'

1 (L4)

- (d) any **one** from
- it was attracted to the base
accept 'the magnets are attracting'
accept 'the N and S poles attract'
 - it moved down
accept 'it would not float'
 - it sank
accept 'it would stick to the base'

1 (L4)

[5]

Q3.

- (a) any **one** from
- goggles
accept 'safety glasses'
'glasses' is insufficient
 - hairband
accept 'hair tied back'
'lab coat' is insufficient
'using tongs' or 'a heat-proof mat' is insufficient

1 (L3)

- (b) • 50 seconds

1 (L3)

- (c) (i) **both** the tick and the matching explanation are required for the mark

- yes ✓
 - crisp A was the biggest and it burnt for 80 seconds
accept 'crisp A burnt for the longest time'
accept 'the biggest crisp burnt for 80s'
'crisp A burnt for a long time' is insufficient
'crisp D burnt for the shortest time' is insufficient
- or**
- no ✓
 - crisp B was the smallest and it burnt for longer than crisp D
accept 'the smallest crisp did not burn for the least time'
accept 'crisp B did not burn for the shortest time'

accept 'Joanne's test was not fair'
accept 'C and D are the same size but burn for different times'

1 (L4)

(ii) any **one** from

- they were not all the same type **or** make
accept 'different shapes'
'the crisps are different sizes' is insufficient
- two were crinkled crisps
accept 'the crisps were from a different packet'
'the crisps were different' is insufficient

1 (L4)

(d) • false ✓

1 (L4)

• false ✓

1 (L4)

• cannot tell ✓

1 (L4)

if more than one box is ticked in any row, do not award a mark for that row

[7]

Q4.

- (a) (i) • the height the ball was dropped from
accept 'height'
do **not** accept 'depth'
accept 'height in cm'
'cm' is insufficient

1 (L5)

(ii) any **one** from

- he repeated it
accept 'he got more results'
accept 'he did it twice'
'it was a fair test' is insufficient
- he could get an average
accept 'he would notice odd results'
- it was more reliable
accept 'more accurate'

1 (L5)

- (b) • the greater the height, the deeper the crater
accept the converse
accept 'there is a positive correlation (between the variables)'

accept 'bigger' for 'deeper' only when it refers to the crater size

a comparative answer is required for the mark
'when the ball was dropped from a high height, a larger crater formed' is insufficient
'the bigger, the deeper' is insufficient as 'bigger' is ambiguous

1 (L5)

(c) any **two** from

- (use the same) ball
accept 'the size **or** mass **or** weight **or** volume **or** material of the ball'
do **not** accept 'density of ball'
- depth of sand
accept 'same amount of sand' **or** 'the (same) sand'
- the conditions of the sand
accept 'how damp the sand was' **or** 'the type of sand'
accept 'how flat the sand surface is'
'the sand tray' is insufficient
- where **or** how the depth is measured
accept 'keep the ruler in the same position'
'use the same ruler' is insufficient
- the way the ball is released
accept 'release the ball with the same force'
'same person' is insufficient

2 (L5)

- (d) (i) • there is less disturbance to the sand
accept 'he might push the ball further in'
accept 'your finger could push it further in, but the magnet lifts it'
'it would be more accurate' is insufficient
accept 'it lifts the ball out cleanly'
'it lifts the ball out' is insufficient

1 (L5)

(ii) any **one** from

- less chance of human error
accept 'the ball would fall the same way each time'
do **not** accept 'there is less chance of something going wrong'
- the electromagnet would drop it cleanly
accept 'the ball would not be dropped differently'
'it lands in the same place' is insufficient
accept 'it drops at the same angle'
'it is easier to adjust height' is insufficient

accept 'the ball would be released from the same height each time'

- the height would be more accurate
'it is more accurate' is insufficient
'so it is a fair test' is insufficient
accept 'they could push the ball (slightly) if they use their hands'
*do **not** accept 'he can change the force of the electromagnet'*
'it stays steady' is insufficient

1 (L6)

[7]

Q5.

(a) any **one** from

- to make the measurements reliable
accept 'it is hard to measure a bent finger'
- to make it fair
- make sure the measurement is correct
accept 'the measurement would be wrong'
- to make it accurate

1 (L3)

(b) (i) mm

accept 'millimetres'

1 (L4)

(ii) any **one** from

- some of the lengths appear in more than one bar
*accept 'they did 65 twice **or** three times'*
- some people were counted twice
- the range varies for the bars
accept correct references to specific numbers
*eg 'they could not record 55.5 **or** 60.5 mm'*
- some lengths are missed out
accept suggestions for improving the bar chart
such as 'the last bar should be 71–75'
'the number are written wrongly' is insufficient

1 (L4)

(c) observe pupils' tongues ✓

if more than one box is ticked, award no mark

1 (L4)

(d) a bar drawn to 10

1 (L3)

- (e) more children were recorded in investigation 1 than in investigation 2
accept the converse
accept '16 children recorded with measurements 50–60 mm. Only 14 children recorded in investigation 2'
accept '36 people in the first investigation, but only 14 in the second'
accept 'there are more higher bars'
accept 'higher bars'
accept 'they add up to different numbers'
numbers need not be precise for this mark
*do **not** accept an answer which only compares the number of bars on the bar charts*

1 (L4)

[6]

Q6.

- (a) any **one** from

- not enough oxygen can get to the candle
accept 'all the oxygen has been used up'
responses referring to 'air' are insufficient
- there is not enough oxygen
accept 'no (more) oxygen'
accept 'O₂ runs out'
'the candle needs oxygen' is insufficient
accept 'carbon dioxide extinguishes the candle'
'it suffocates' is insufficient
accept 'there is too much carbon dioxide'

1 (L5)

- (b) (i) • all five points plotted correctly
accept points plotted within ± 1 small square

1 (L5)

- (ii) • an appropriate line of best fit for the plotted points

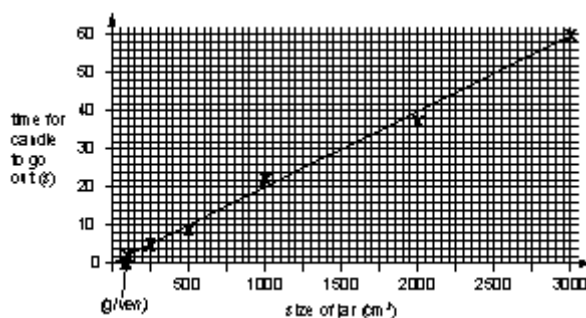

accept a line or curve consistent with the points plotted

1 (L5)

- (iii) • the bigger the jar the longer the candle takes to go out
accept the converse
accept 'there is a positive correlation between the size of the jar and the time the candle stays lit'

'burning needs oxygen' is insufficient
'it takes the candle a longer time to go out in a big jar' is insufficient
accept 'the bigger the jar or the greater the volume of the oxygen or air, the longer the flame stays alight'
'a bigger jar contains more air or oxygen' is insufficient

1 (L5)

(c) any **one** from

- type of candle
accept 'candle'
do not accept 'time the candle takes to go out'
- the surface the jar is on
- shape of jar
do not accept 'volume or size of jar'

1 (L5)

- (d) • repeat the experiment **or** measurements
accept 'take more measurements'
do not accept 'make the test fair'
accept 'take more accurate measurements'
accept 'use more jars (between 1000 cm³ and 3000 cm³)'
(L5)

1

[6]