

Name:

School:



TONBRIDGE SCHOOL

Scholarship Examination Sample Paper

Science II – Biology, Chemistry and Physics

Time allowed: 1 hour 15 minutes

Please write your name at the top of each of the subject specific sections, as indicated.

Answer all the Questions.

You may use a calculator.

The entire paper is worth 60 marks and the number of marks for each question is shown in brackets.

1. One of the characteristics of living organisms is that they reproduce. Many organisms use a process called sexual reproduction in order to produce offspring. During this process two cells, one from each parent, combine.

a. What name is given to the specialised cells produced by each parent? (1)

.....

b. Each gender produces specialised sex cells. Complete the table below using the key terms given. (3)

Sessile Small Few Many Mobile Large

Feature of Sex Cell	Male Sex Cell	Female Sex Cell
Size		
Number		
Mobility		

c. Once the sex cells have fused in mammals a baby may grow. In order for the baby to grow it will need to undertake a process called respiration. In the space below write a word equation for this process. (2)

.....

- d. In humans the raw materials for this process come from the mother's body and the waste material is excreted by the mother. In birds this is not the case. Would you expect an egg to get heavier, lighter or stay the same mass as the chick grows?

Please explain your answer.

(3)

.....

.....

.....

.....

.....

2. Jan Baptist van Helmont was a Belgian scientist. He studied plants. At the time it was thought that plants grew heavier by consuming material in the soil. van Helmont decided to design an experiment to test this.



Van Helmont's tree when he planted it

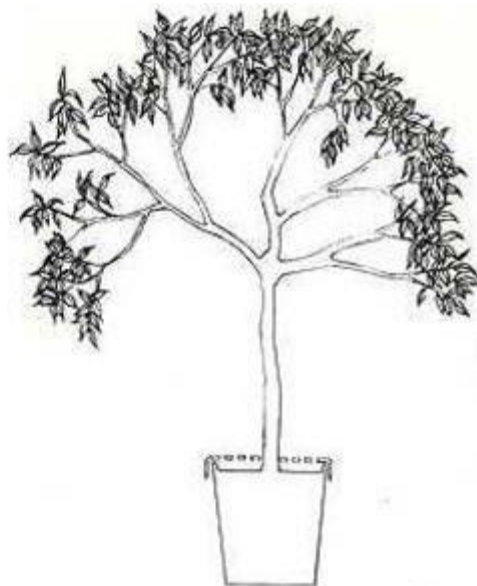

Van Helmont's tree after five years

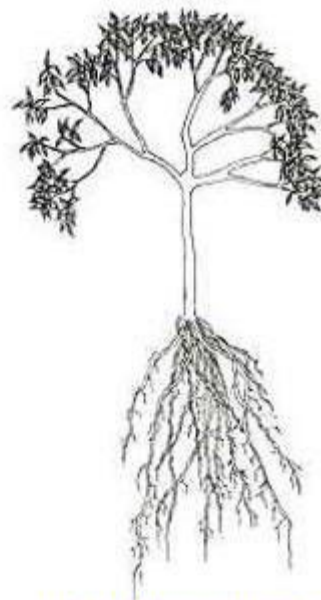

Van Helmont's tree after five years, out of its pot to show the roots

- a. Fill in the table below to show the mass of the plant at the start and end of the experiment. (1)

	Mass of Soil (kg)	Mass of Plant and Soil (kg)	Mass of Plant (kg)
Start	90.0	92.2	
5 years later	89.5	166.1	

- b. To what extent do the results of this experiment conflict with the thinking of the time? (1)

.....

.....

.....

- c. van Helmont concluded that the gain in mass of the plant must come from the water he had given it whilst it grew. Use your knowledge of Chemistry to dispute his conclusion (2)

.....

.....

.....

.....

.....

- d. Science requires empirical proof of a hypothesis. Design an experiment to test van Helmont's hypothesis that a plant gains mass from the water given to it. Consider in your experiment which variables you will change, which you will measure and which you will keep constant.

(4)

.....

.....

.....

.....

.....

.....

.....

.....

3. An adaptation is a feature of an organism or its behaviour that helps an organism to survive and reproduce. Outline your favourite adaptation, this can be taken from any organism, and explain how it helps the organism survive and reproduce.

(3)

.....

.....

.....

.....

.....

.....

.....

.....

BLANK PAGE

Chemistry

Name: _____

1. This question is about Particle Theory. A student places 20.0cm^3 of water into a measuring cylinder that is sitting on a top pan balance. She finds the mass to be 20g. She places it in a freezer overnight and finds that the resulting ice has a volume of 21.7cm^3 .

a. Name the process in which water is converted to ice. (1)

.....

b. Explain why the volume has increased. (1)

.....

c. Predict the mass of ice in the measuring cylinder. Explain your answer. (2)

.....

.....

.....

2. Magnesium is reacted with oxygen in an open beaker. There is a bright white light and the white solid is formed.



a. Is this change chemical or physical? Explain your answer. (2)

.....

.....

.....

b. What happens to the mass of the beaker and solid? Tick your answer (1)

- Increases
- Decreases
- Stays the Same

c. Explain your answer. (1)

.....

.....

The experiment is repeated with the magnesium in a **sealed** container.

d. What happens to the mass of the sealed container? Tick your answer (1)

- Increases
- Decreases
- Stays the Same

e. Explain your answer. (1)

.....

.....

f. Which of the following processes is endothermic? Tick your answer (1)

- Deposition
- Condensation
- Freezing

3. This question is all about metal displacement reactions. The table below shows the temperature change when metals are added to a solution of Copper (II) Sulphate, CuSO_4 .

Metal	Tin	Calcium	Zinc	Magnesium
Temperature Change / $^{\circ}\text{C}$	4	32	21	27

- a. Plot a suitable graph for this data. You should choose an appropriate scale and label the axes. (4)

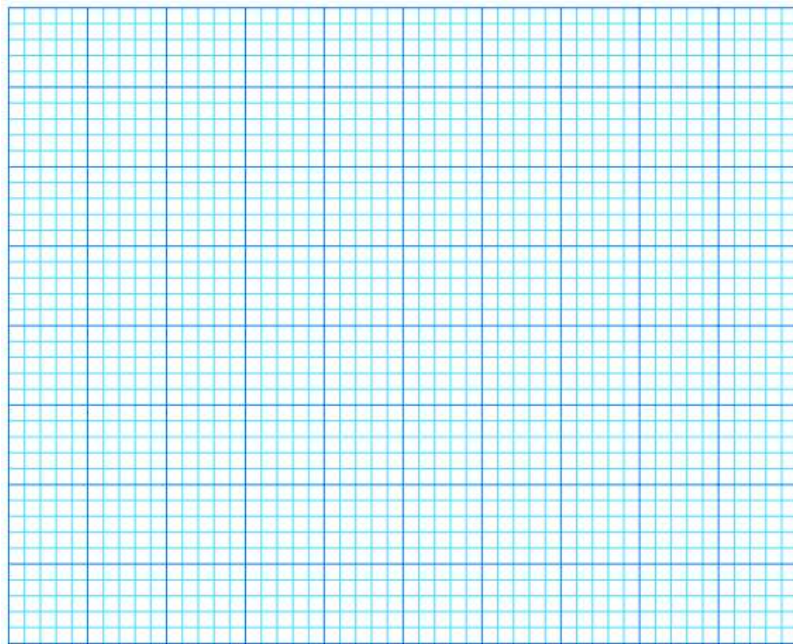

- b. In each case, a solid is produced in the reaction. Predict the colour of this solid. (1)

.....

A reactivity series is shown below;

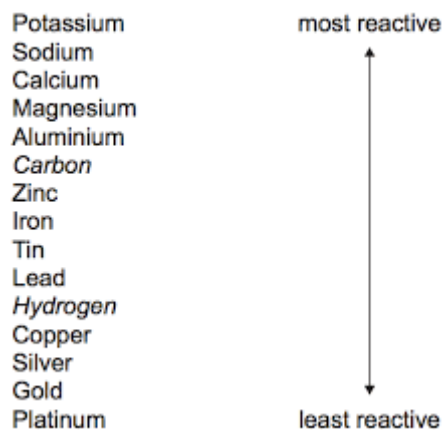

- c. Predict the temperature change when Iron is reacted with Copper (II) Sulphate. (1)

.....
.....

When metal, M, is put into water, bubbles of gas given off and the metal eventually disappears. The resulting solution has pH14.

- d. Suggest a possible identity for metal M (1)

.....
.....

Gold has a number of uses in the modern world:

- e. Give a use of Gold metal (1)

.....
.....

- f. Explain, in terms of its chemical or physical properties, why it is suitable for that use. (1)

.....
.....

Chemistry Total Marks 20

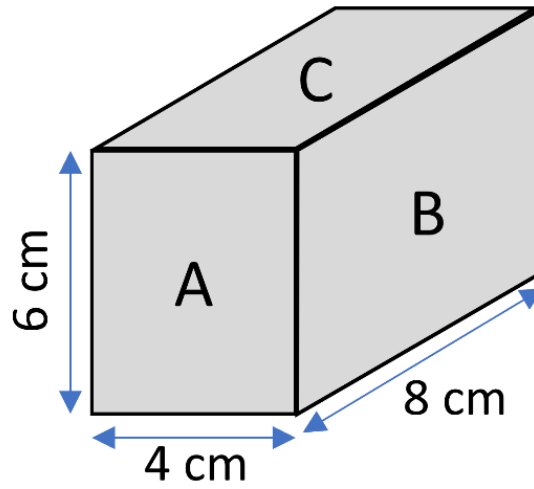

1. A cuboid has side lengths 4.0cm, 6.0cm and 8.0cm.

a. Calculate the volume of the cuboid (2)

.....

.....

.....

.....

b. The cuboid has a density of 5.0g/cm^3 . Calculate the mass of the cuboid (3)

.....

.....

.....

.....

- c. The cube is placed with one side on the floor. Which side will produce the largest pressure? (1)

.....
.....

[Ignore any effects of air resistance during the following question]

2. A ball has a long piece of tape attached to it which runs through a machine that marks dots on the paper every 0.1s. The ball is dropped and hits the floor. The first dot is made when the ball is released, and the last dot being made when it hits the floor.

- a. Using the scale 1cm = 10cm, calculate the height from which the ball was dropped (2)

.....
.....

- b. How long did it take for the ball to hit the floor? (2)

.....
.....

- c. Hence calculate the average speed of the ball: (3)

.....
.....
.....
.....



d. When was the ball travelling at the average speed? (1)

- At half the distance between its release height and the floor
- At half the time through its flight
- Throughout its journey
- It never was travelling at exactly its average speed

e. A second heavier ball was also dropped at the same time. The time it took for the second ball to fall to the ground was: (1)

- Less than the lighter ball
- The same as the lighter ball
- Longer than the lighter ball

3. A simple circuit is made with a bulb (labelled A) and a cell. The brightness of bulb A is recorded. A second, identical bulb (labelled B) is added to the circuit so that the two bulbs are in line. The brightness of the bulbs A & B is again recorded and compared to the first result:

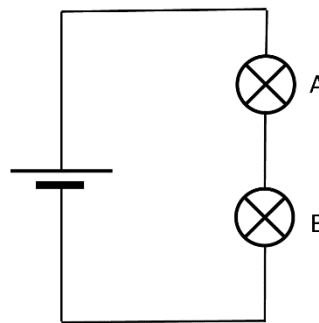
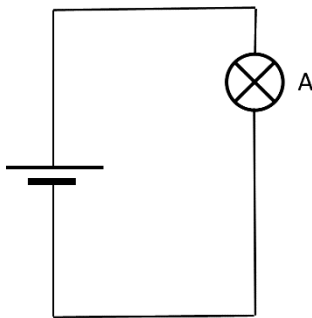

a. In the second circuit, how does the brightness of bulb A compare with that of B? (1)

- A is Brighter
- They are the same
- A is dimmer

b. Which of the following statements is true: (1)

- Bulb A got dimmer when bulb B was added
- Bulb A stayed the same brightness even after bulb B was added
- Bulb A got brighter after bulb B was added

A new circuit is made with bulbs A and B, as well as three switches. The diagram below shows the configuration. The three switches can be open and closed and the bulbs may light up:

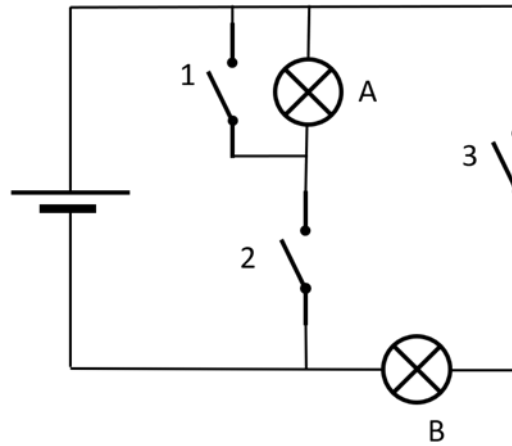

c. Complete the table below. The first row is completed for you: (5)

<u>Switch 1</u>	<u>Switch 2</u>	<u>Switch 3</u>	<u>Bulb A</u>	<u>Bulb B</u>
open	open	closed	off	on
closed	closed	open		
open	closed	closed		
open	closed	open		
closed	open	closed		
closed	closed	closed		

Physics Total Marks 20

END OF PAPER 2