

## Year 9 mathematics test

# Paper 2

## Calculator allowed

First name \_\_\_\_\_

Last name \_\_\_\_\_

Class \_\_\_\_\_

Date \_\_\_\_\_

Please read this page, but do not open your booklet until your teacher tells you to start. Write your name, the name of your class and the date in the spaces above.

### Remember:

- The test is 1 hour long.
- You **may** use a calculator for any question in this test.
- You will need: a pen, pencil, rubber, ruler, a pair of compasses and a scientific or graphic calculator.
- Some formulae you might need are on page 2.
- This test starts with easier questions.
- Try to answer all the questions.
- Write all your answers and working on the test paper – do not use any rough paper. Marks may be awarded for working.
- Check your work carefully.
- Ask your teacher if you are not sure what to do.

## Instructions

### Answers



This means write down your answer or show your working and write down your answer.

### Calculators



You **may** use a calculator to answer any question in this test.

## Formulae

You might need to use these formulae

### Trapezium

$$\text{Area} = \frac{1}{2}(a + b)h$$

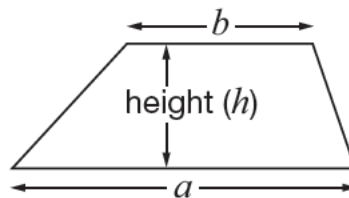

### Prism

area of cross-section

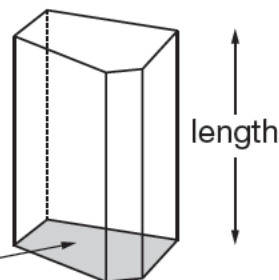

$$\text{Volume} = \text{area of cross-section} \times \text{length}$$

1. Here are four spinners, labelled A, B, C and D.

I am going to spin each pointer.

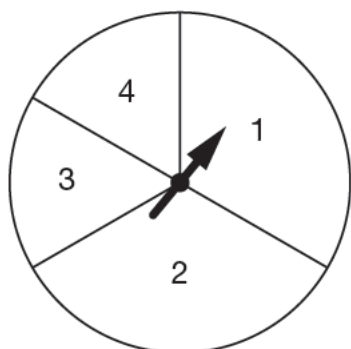

A

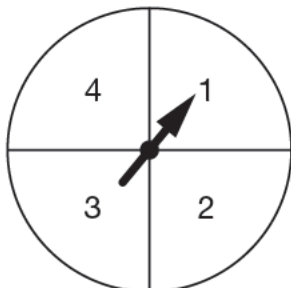

B

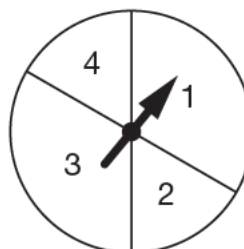

C

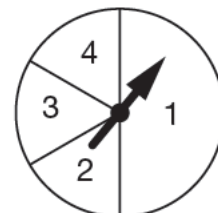

D

(a) Which spinner gives the **greatest chance** that the pointer will stop on **3**?



Spinner \_\_\_\_\_

1 mark

(b) Which spinner gives the **least chance** that the pointer will stop on **1**?



Spinner \_\_\_\_\_

1 mark

(c) This spinner is divided into eight equal sectors.

Write a number in each sector so that there is a **50% chance** that the pointer will stop on **2**

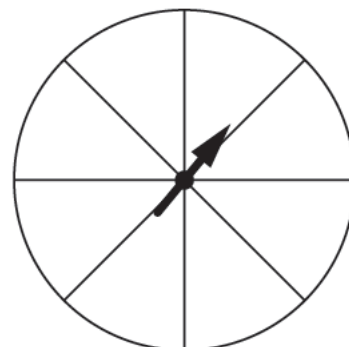

1 mark



2. Jim's clock shows:

<div style="border: 1px solid black; padding: 5px; display: inline-block;">22 : 00</div>	15 November
--	-------------

What will Jim's clock show in exactly **3 hours** time?

<div style="border: 1px solid black; width: 100px; height: 40px; display: flex; align-items: center; justify-content: center; margin: 0 auto;"> <span style="font-size: 2em;">:</span> </div>	<div style="border-bottom: 1px solid black; width: 50px; display: inline-block; margin-right: 5px;"></div> November
---	---

\_\_\_\_\_

2 marks

3. Write numbers to make these calculations correct.

The first one is done for you.

$$\boxed{21} \div \boxed{5} = 4 \text{ remainder } 1$$

$$\img alt="pencil icon" style="vertical-align: middle;"/> \boxed{\phantom{00}} \div \boxed{8} = 4 \text{ remainder } 2$$

\_\_\_\_\_

1 mark

$$\img alt="pencil icon" style="vertical-align: middle;"/> \boxed{\phantom{00}} \div \boxed{\phantom{00}} = 4 \text{ remainder } 3$$

\_\_\_\_\_

1 mark

4. A website gives this chart to show the chair and table heights for children.

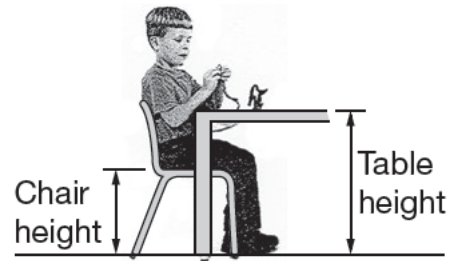

Chair height (inches)	10	12	14	16
Table height (inches)	18	20	22	24–26
4 year-olds	40%	60%		
5 year-olds		100%		
6 year-olds		50%	50%	
7 year-olds		20%	80%	
8 year-olds			80%	20%
9 year-olds			40%	60%
10 year-olds				100%

- (a) 50% of **6 year-olds** need a chair height of 12 inches and a table height of 20 inches.

What do the other 50% of 6 year-olds need?



Chair height: \_\_\_\_\_ inches      Table height: \_\_\_\_\_ inches

1 mark

- (b) Gill says:

More than three-quarters of all **8 year-olds** need a chair height of 14 inches.

Is she correct?



Yes

No

Explain your answer.



1 mark



5. Jack has forgotten his PIN.

He can remember that it is a four-digit number starting with 9 and ending with 3

9	?	?	3
---	---	---	---

He also knows that the first two digits add up to the same as the last two digits.

Write down **all the numbers** that his PIN could be.



2 marks

6. Write the missing values in this table.

$y$	$2y$	$y^2$
3	6	
2		
		36

2 marks

7. Kate wants to decorate **all four walls** of a rectangular room.

Here are the dimensions of her room.

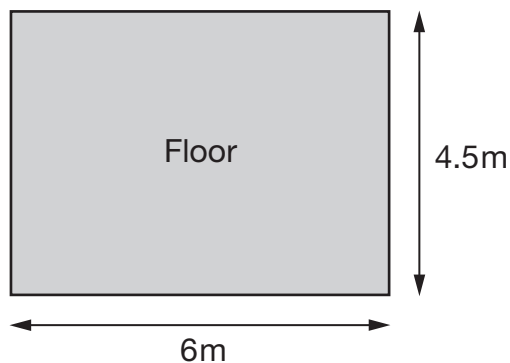

The table shows the number of rolls of wallpaper needed to decorate different sized rooms.

Distance around the room	Number of rolls needed
10m	6
12m	7
14m	8
16m	9

Kate has **11 rolls** of wallpaper.

Does she have enough to wallpaper her room?



Yes

No

Explain your answer.



2 marks



8. For each statement below, tick (✓) the values of  $n$  for which the statement is **true**.

The first row is done for you.

	$n = 4$	$n = 5$	$n = 6$	$n = 7$
$n$ is greater than 5			✓	✓
$2n$ is equal to 10				
$2 + n$ is less than 8				
$n^2$ is less than 30				

\_\_\_\_\_

\_\_\_\_\_

2 marks



9. (a) In a triangle, the largest angle is **20 degrees larger** than the smallest angle.

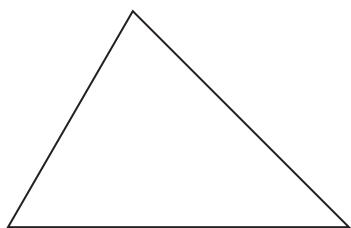

Not drawn accurately

Write down what the three angles could be for this triangle.







\_\_\_\_\_

2 marks

- (b) Another triangle has an **obtuse** angle.

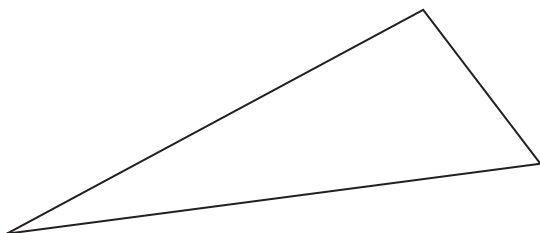
The obtuse angle is 20 degrees larger than one of the other angles.



Not drawn accurately

Write down what the three angles could be for this triangle.







\_\_\_\_\_

2 marks

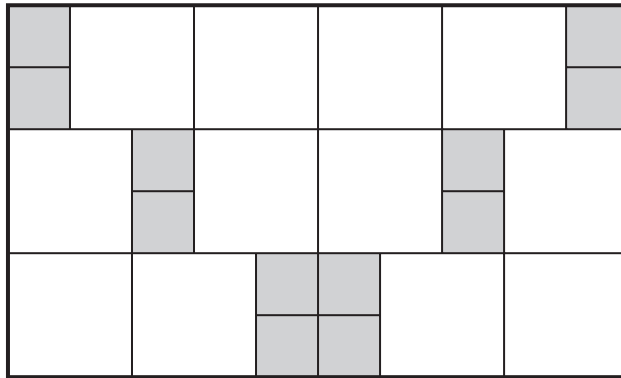

10. This large rectangle is made from white squares and smaller grey squares.



Not drawn  
full size

The area of one **grey** square is  $1\text{cm}^2$

What is the area of the large rectangle?



\_\_\_\_\_  $\text{cm}^2$

2 marks

11. Write the missing numbers in the boxes.

  $0.06 + \boxed{\phantom{00}} = 1$

1 mark

  $0.6 + 0.06 + \boxed{\phantom{00}} = 1$

1 mark

12. A swimming pool has this price list.

### Swimming Pool Price List

	Price	
	Adult	Child
Annual Membership	£230.00	£180.00
Monthly Membership	£26.50	£15.00
Casual Swim	£3.50	£1.65
Add-on Membership	£7.00 for each child	
Family Swim	£7.25	

**Annual Membership:** Unlimited swimming for a year.

**Monthly Membership:** Unlimited swimming for one month.

**Add-on Membership:** Add up to 3 children to an adult Monthly Membership.

**Family Swim:** 2 adults and 2 children. Pay on entry.

A father and his two children want to swim twice a week for a year.

What is the **minimum** cost **per month** for them to do this?



£  per month

3 marks



13. The diagram shows a rectangle.  
The dotted line is a diagonal of the rectangle.

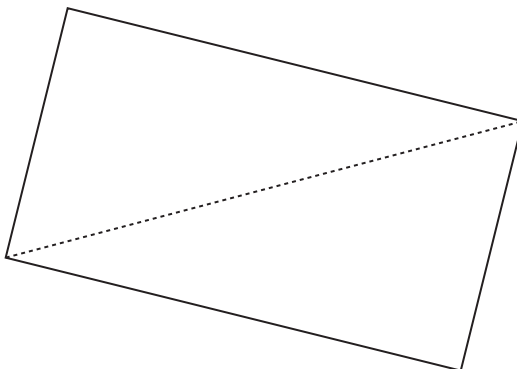

Below is a diagonal of a different rectangle.

The dimensions of the rectangle are **6cm by 8cm**.

Use a pair of compasses and a ruler to draw the rectangle.

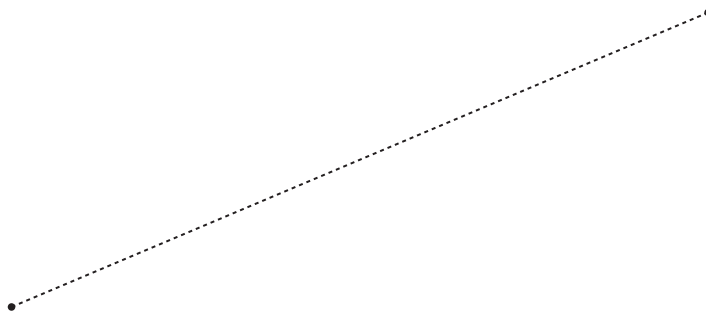

2 marks

14. A word game has tiles with letters on.  
Some letters are more common than others.

- (a) There are **100 tiles** in the English version of the game.

Here is information about how many tiles show the letter A, E or O.



9 tiles



12 tiles



8 tiles

I am going to take one of the 100 tiles at random.

What is the **probability** that it will show one of the letters A, E or O?



1 mark

- (b) There are **104 tiles** in the Russian version of the game.

The probability that a tile taken at random will show A, E or O is  $\frac{1}{4}$

The ratio of tiles showing A, E or O is **4 : 4 : 5**

Work out how many of the 104 tiles show the letters A, E or O.



\_\_\_\_\_ tiles



\_\_\_\_\_ tiles



\_\_\_\_\_ tiles

2 marks



15. I have **16 cubes** that are all the same size.

I join the 16 cubes together to make the cuboid shown below.

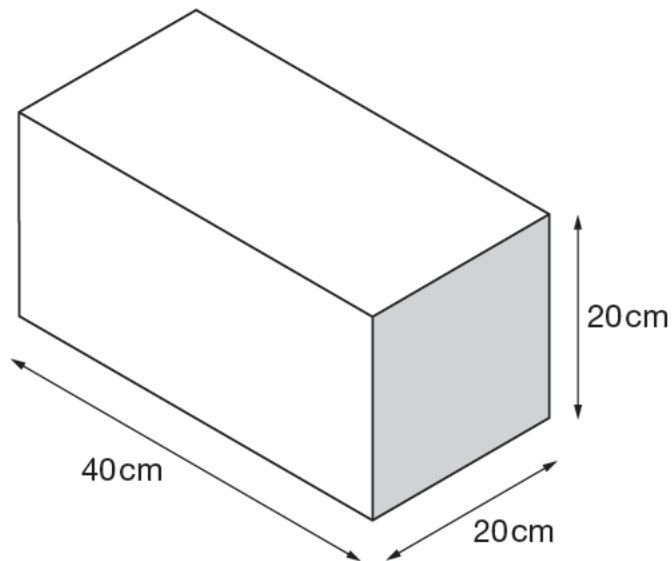

Not drawn accurately

What is the **side length** of one of my cubes?



\_\_\_\_\_ cm

\_\_\_\_\_

2 marks

16. The diagrams show how the average height of a 7 year-old child in China changed from 1957 to 2007.

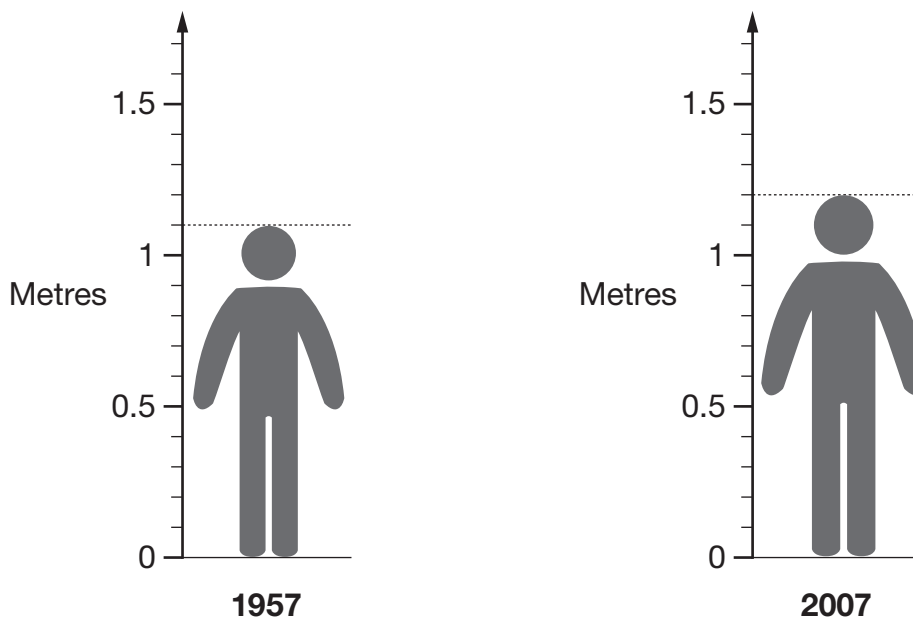

- (a) The average height of a 7 year-old child in China has increased over these 50 years. By how many **centimetres per year** has it increased?



1 mark

- (b) In 2007, the average height of a woman in China was **30% more** than the average height of a 7 year-old child.

What was the average height of a woman in China in 2007?



2 marks



17. Look at the diagram.  
The square has a side length of 7cm.  
The circle fits exactly inside the square.

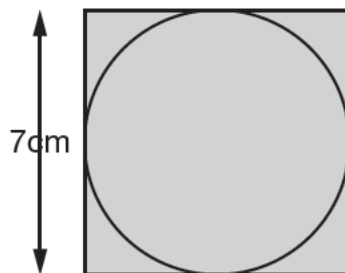

Not drawn  
accurately

Work out the area of the circle.

 \_\_\_\_\_ cm<sup>2</sup>

1 mark



18. The graph shows how the price of lemons in America has changed.

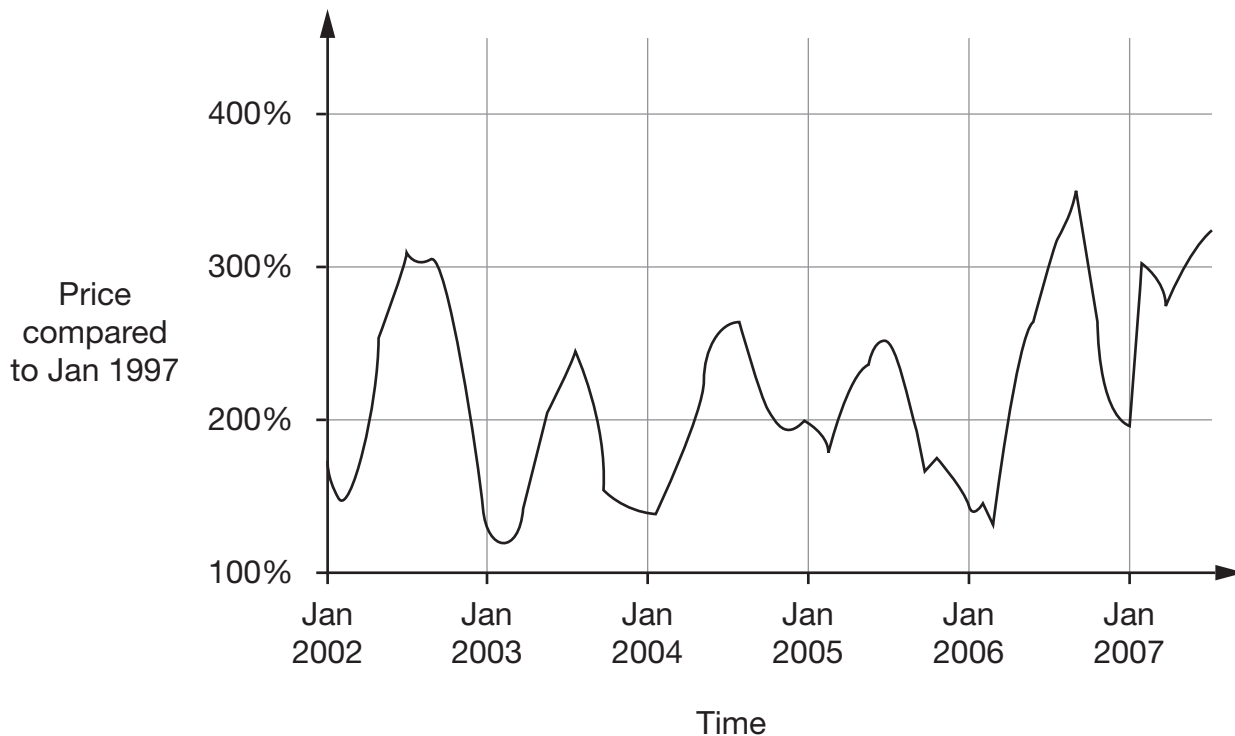

- (a) The price of lemons was **lowest** in about **March 2003**.

When was the price of lemons the **highest**?



About \_\_\_\_\_

1 mark

- (b) Usually, about what time of year are lemons **most expensive** in America?



\_\_\_\_\_

1 mark



19. Each year, the Bank of England prints new banknotes.

The chart shows how many banknotes were printed in 2006.

**Number of banknotes printed in 2006**

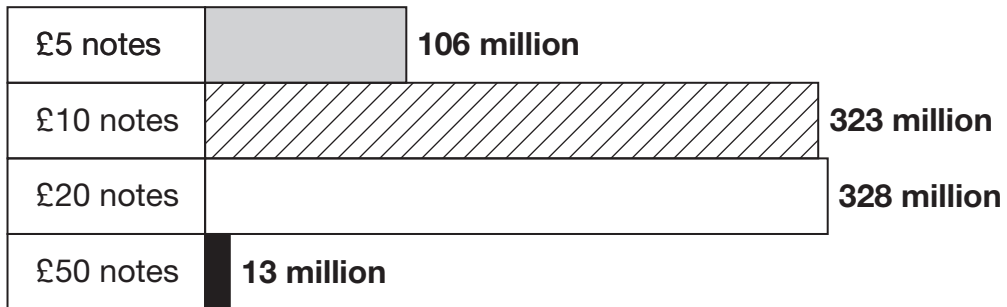

- (a) What was the **total value** of the banknotes printed in 2006?



£	million
---	---------

2 marks

- (b) The Bank of England will replace banknotes that have been damaged or destroyed. The pie chart shows how banknotes were damaged or destroyed in 2006.

**Number of banknotes damaged or destroyed in 2006**

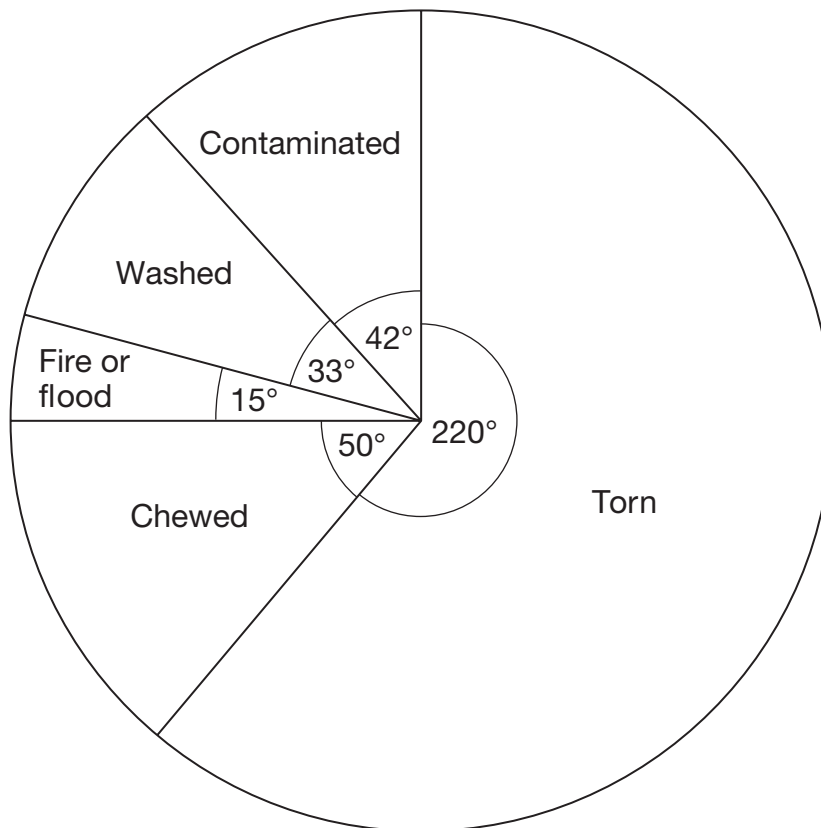

Altogether, **35 525 million** banknotes were damaged or destroyed.

About how many of these were **chewed**?



million

2 marks



20. Street lights are going to be put on a new stretch of motorway.

Two types of light can be used.

	Height	Cost (each)
Type A	12m	£4200
Type B	15m	£5025

The motorway is **5km** long.

The distance from one light to the next must be no more than  $2\frac{1}{2}$  times the height of the light.

Which type of light is cheaper for this stretch of motorway and how much will these lights cost altogether?



\_\_\_\_\_  
\_\_\_\_\_  
\_\_\_\_\_  
\_\_\_\_\_  
4 marks

21. To check whether a man is the right weight for his height, a doctor uses this formula for the Body Mass Index (BMI)

$$\text{BMI} = \frac{W}{H^2}$$

where  $W$  is the weight in kg and  $H$  is the height in metres (m).

The table below classifies the result.

BMI	Classification
Less than 18.5	Underweight
From 18.5 to 24.9	Normal weight
From 25.0 to 29.9	Overweight
30.0 or more	Obese

A man has a height of **1.85m** and weight of **95kg**.

How much weight should he **lose** to be classed as having a **normal weight**?



3 marks

22. Scientists have measured the amount of CO<sub>2</sub> in the atmosphere since 1958. The graph shows the results.

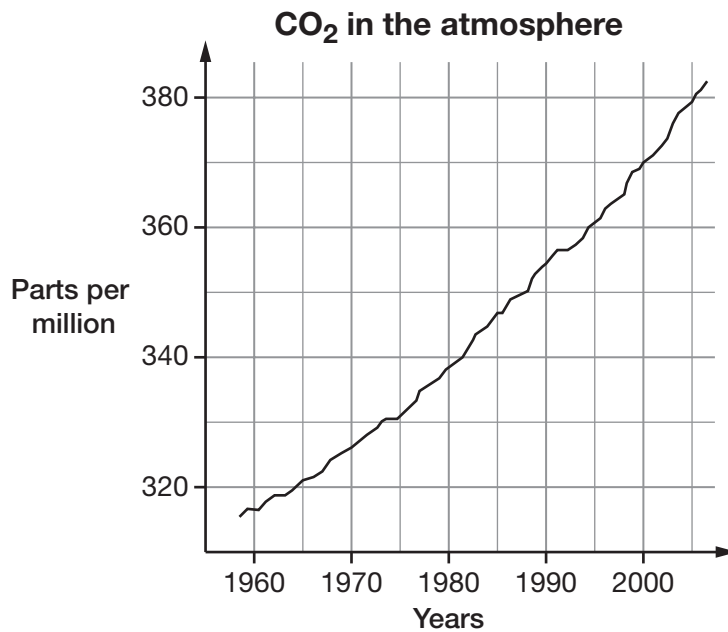

John and Michael look at the graph.

John says:

*'There was about seven times as much CO<sub>2</sub> in the atmosphere in 2005 as there was in 1965.'*

Michael says:

*'No, the increase was only about 20%.'*

Who is right? Tick (✓) the correct box.



John

Michael

Show working to explain your answer.



2 marks

23. The area of this rectangle is  $18\text{cm}^2$   
 The perimeter is  $18\text{cm}$ .  
 The values are equal.

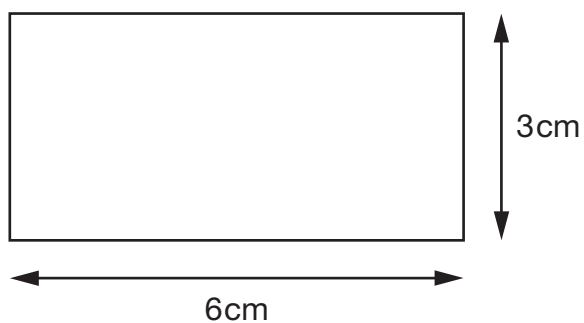

What value of  $y$  makes the area and perimeter of this L-shape equal in value?

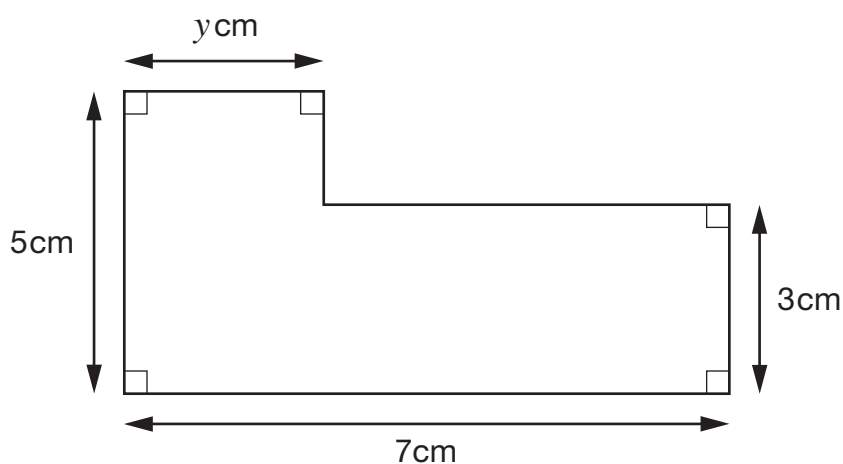

Not drawn accurately



$$y = \underline{\hspace{2cm}}$$

2 marks



24. (a) Show that there are between  $10^3$  and  $10^4$  minutes in a day.



---

1 mark

(b) How many **seconds** are there in a day?

Put a ring around the correct answer below.



Between  $10^3$  and  $10^4$

Between  $10^4$  and  $10^5$

Between  $10^5$  and  $10^6$

Between  $10^6$  and  $10^7$

More than  $10^7$

---

1 mark



25. The diagram shows an equilateral triangle that just touches the sides of a circle.

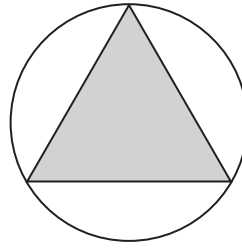

For an equilateral triangle of side length 10cm, the radius of the circle,  $r$ , is

$$r = \frac{1000}{4\sqrt{15}(15 - 10)^3}$$

Work out the value of  $r$

Give your answer correct to 1 decimal place.



$$r = \text{_____ cm}$$

2 marks



**END OF TEST**

**BLANK PAGE**

**BLANK PAGE**