

National curriculum tests

Key stage 2

Mathematics

Paper 2: reasoning

First name						
Middle name						
Last name						
Date of birth	Day		Month		Year	
School name						

SAMPLE BOOKLET

Published July 2015

This sample test indicates how the national curriculum will be assessed from 2016. Further information is available on GOV.UK at www.gov.uk/sta.



PUPIL ID NUMBER



[BLANK PAGE]

Please do not write on this page.



Instructions

You **may not** use a calculator to answer any questions in this test.

Questions and answers

You have **40 minutes** to complete this test.

Follow the instructions for each question.

Work as quickly and as carefully as you can.

If you need to do working out, you can use the space around the question.

Do not write over any barcodes.

Some questions have a method box like this:

Show your method

For these questions you may get a mark for showing your method.

If you cannot do one of the questions, **go on to the next one.**

You can come back to it later, if you have time.

If you finish before the end, **go back and check your work.**

Marks

The number under each line at the side of the page tells you the maximum number of marks for each question.



1

Write the missing number.

One is done for you.

180 $\xrightarrow{\text{is 20 more than}}$ 160

$\xrightarrow{\text{is 20 more than}}$ 237

1 mark

2

A pack of paper has 150 sheets.

4 children each take 7 sheets.

How many sheets of paper are left in the packet?

Show
your
method

A large grid for showing the method to solve the problem. A smaller empty rectangular box is drawn on the grid.

2 marks

3

This graph shows the temperature in six cities on one day in January.

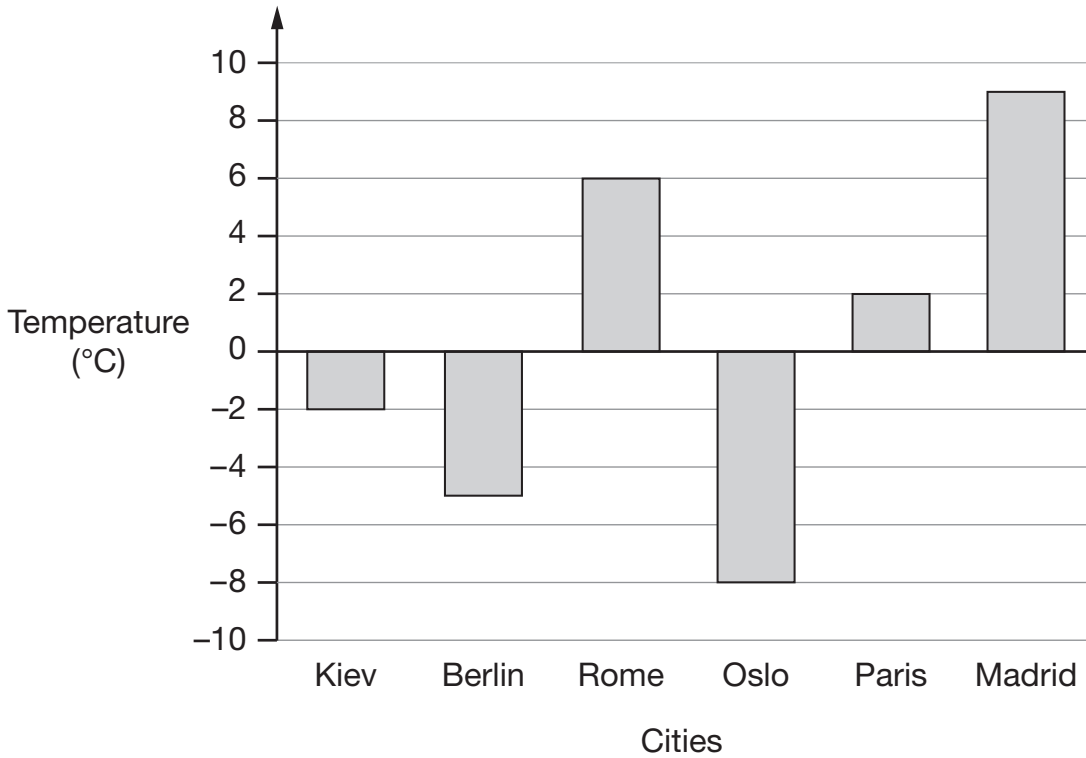

Which city was 4 degrees **warmer** than Kiev?

1 mark

What was the **difference** between the temperature in Oslo and the temperature in Berlin?

°C

1 mark



4

Here are some shapes made of squares.

A fraction of each shape is shaded.

Match each shape to its equivalent fraction.

One has been done for you.



$$\frac{7}{10}$$

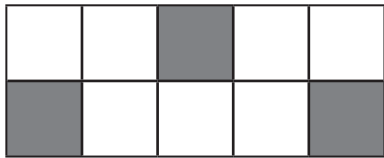

$$\frac{3}{5}$$



$$\frac{1}{2}$$

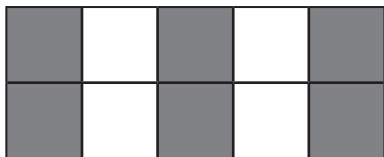

$$\frac{4}{5}$$

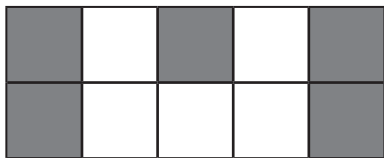

$$\frac{3}{10}$$

2 marks

5

What is 444 minutes in hours and minutes?

hours

minutes

1 mark

6

Stefan's watch shows five minutes past nine.

The watch is twelve minutes fast.



What is the correct time?

1 mark

7

In the circles, write a multiple that belongs to each set.

One has been done for you.

numbers from 1 to 99

multiple of **10**

50

numbers from 101 to 199

multiple of **20**

numbers from 201 to 299

multiple of **30**

numbers from 301 to 399

multiple of **40**

2 marks



8

Maria bakes cakes and sells them in bags.



She uses this formula to work out how much to charge for one bag of cakes.

$$\text{Cost} = \text{number of cakes} \times 20\text{p} + 15\text{p for the bag}$$

How much will a bag of 12 cakes cost?

£

1 mark

Olivia buys a bag of cakes for £5.15

Use the formula to calculate how many cakes are in the bag.

Show your method

cakes

2 marks

9

Here is a triangle.

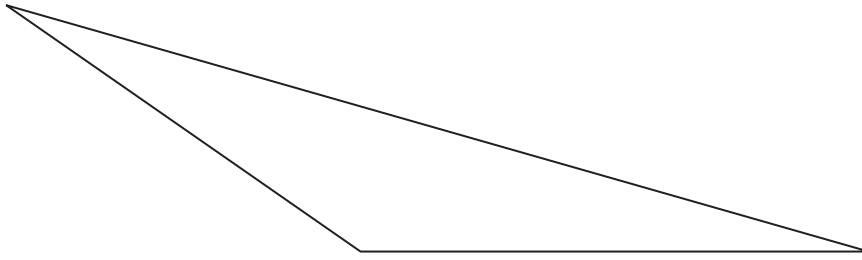

Measure the shortest side accurately, in centimetres.

1 mark

Measure the largest angle.

1 mark

10

Write the two missing digits to make this **long multiplication** correct.

$$\begin{array}{r} \square \\ \square 6 \\ \hline 246 \\ 820 \\ \hline 1066 \end{array}$$

2 marks

11

Here is a number written in Roman numerals.

CXV

Write the number in figures.

1 mark

12

What number is halfway between 1.4 and 2.1?

1 mark



13

The diagram shows a shaded octagon on a square grid.

Line **A** joins two vertices of the octagon.

Join two other vertices to draw a line **parallel** to line **A**.

Use a ruler.

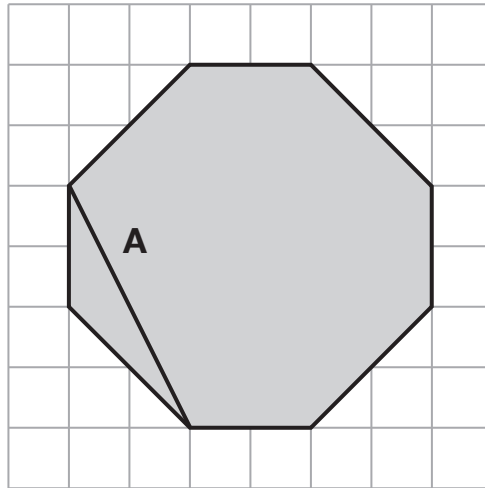

1 mark

Join two vertices to draw a line **perpendicular** to line **A**.

Use a ruler.

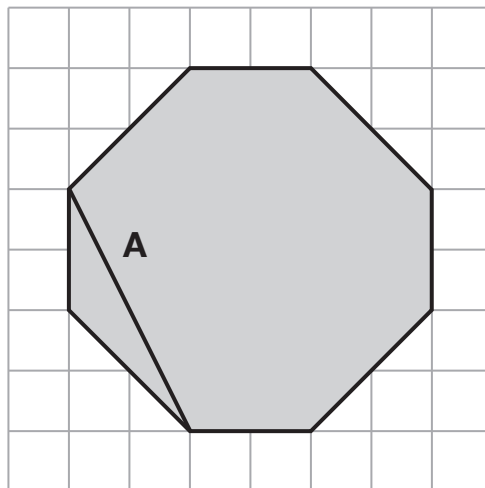

1 mark



14

Round 124,531

to the nearest 10,000

to the nearest 1,000

to the nearest 100

2 marks



15

A shaded **isosceles** triangle is drawn inside a rectangle.

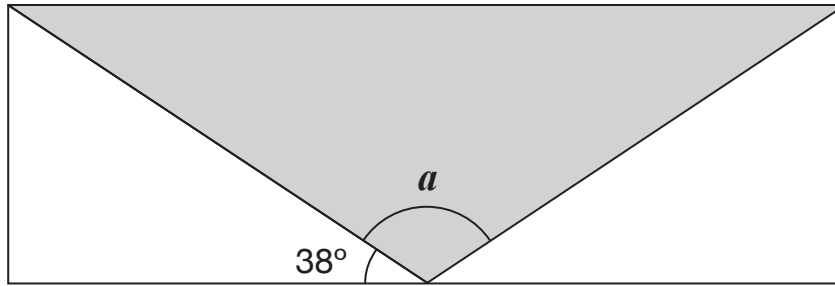

Not
to
scale

Calculate the size of angle a .

Show
your
method

a is	°
--------	---

2 marks



16

Large pizzas cost £8.50 each.

Small pizzas cost £6.75 each.

Five children together buy one large pizza and three small pizzas.

They share the cost equally.

How much does each child pay?

Show
your
method

£

2 marks

17

Seven children measured their heights.

Children	Height (cm)
Stefan	144
Lara	136
Olivia	142
Chen	143
Maria	152
Dev	148
Sarah	150

What is the mean height of the children?

Show
your
method

A large grid for showing the method to calculate the mean height. A small box on the right side of the grid contains the text "cm".

2 marks



18

100 girls and 50 boys were asked which kind of chocolate they like best.

These two pie charts show the results.

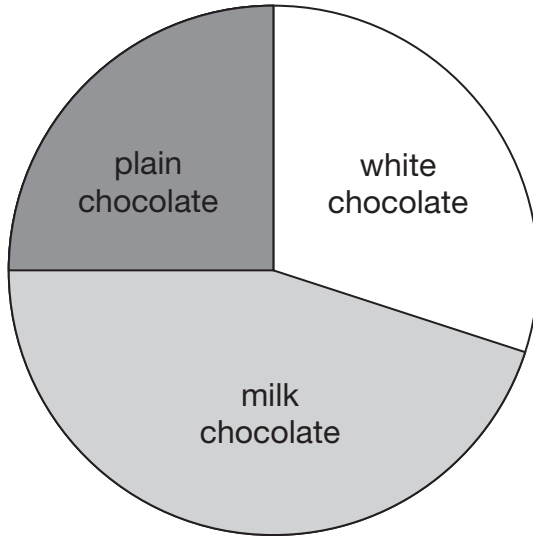

100 girls

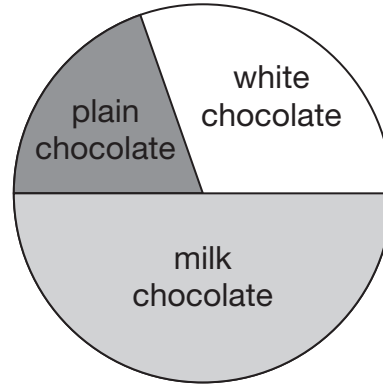

50 boys

Dev says,

“The pie charts show that more girls than boys liked milk chocolate best.”

Dev is correct.

Explain how you know.

A large, empty, cloud-shaped box with a scalloped border, intended for the student to write their explanation.

1 mark

19

One gram of gold costs £32.94

What is the cost of **half a kilogram** of gold?

Show
your
method

£

2 marks

[END OF TEST]

Please do not write on this page.



[BLANK PAGE]

Please do not write on this page.





Standards
& Testing
Agency

Sample key stage 2 mathematics paper 2: reasoning
Electronic PDF version product code: STA/15/7323/e ISBN: 978-1-78315-741-9

For more copies

Additional printed copies of this booklet are not available. It can be downloaded from www.gov.uk/government/publications.

© Crown copyright and Crown information 2015

Re-use of Crown copyright and Crown information in test materials

Subject to the exceptions listed below, the test materials on this website are Crown copyright or Crown information and you may re-use them (not including logos) free of charge in any format or medium in accordance with the terms of the Open Government Licence v3.0 which can be found on the National Archives website and accessed via the following link: www.nationalarchives.gov.uk/doc/open-government-licence. When you use this information under the Open Government Licence v3.0, you should include the following attribution: 'Contains public sector information licensed under the Open Government Licence v3.0' and where possible provide a link to the licence.



Exceptions – third-party copyright content in test materials

You must obtain permission from the relevant copyright owners, as listed in the '2016 sample tests copyright report', for re-use of any third-party copyright content which we have identified in the test materials, as listed below. Alternatively you should remove the unlicensed third-party copyright content and/or replace it with appropriately licensed material.

Third-party content

These materials contain no third-party copyright content.

If you have any queries regarding these test materials contact the national curriculum assessments helpline on 0300 303 3013 or email assessments@education.gov.uk.

