

Ma

KEY STAGE

3

TIER

4-6

2005

# Mathematics test

## Paper 1

### Calculator **not** allowed

Please read this page, but do not open your booklet until your teacher tells you to start. Write your name and the name of your school in the spaces below.

First name \_\_\_\_\_

Last name \_\_\_\_\_

School \_\_\_\_\_

#### Remember

- The test is 1 hour long.
- You **must not** use a calculator for any question in this test.
- You will need: pen, pencil, rubber, ruler and tracing paper (optional).
- Some formulae you might need are on page 2.
- This test starts with easier questions.
- Try to answer all the questions.
- Write all your answers and working on the test paper – do not use any rough paper. Marks may be awarded for working.
- Check your work carefully.
- Ask your teacher if you are not sure what to do.

For marker's  
use only

Total marks

--

## Instructions

### Answers



This means write down your answer or show your working and write down your answer.

### Calculators



You **must not** use a calculator to answer any question in this test.

## Formulae

You might need to use these formulae

### Trapezium

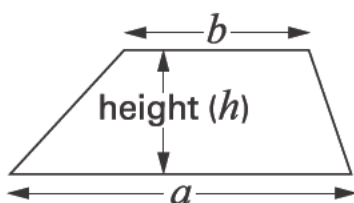

$$\text{Area} = \frac{1}{2}(a + b)h$$

### Prism

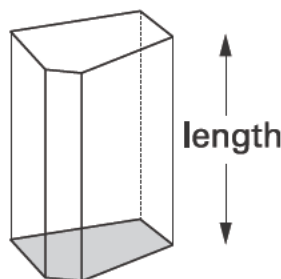

$$\text{Volume} = \text{area of cross-section} \times \text{length}$$

1. Write the missing numbers on the number lines.

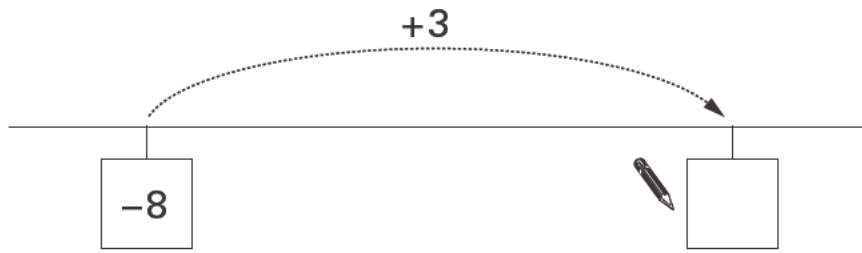

.....  
1 mark

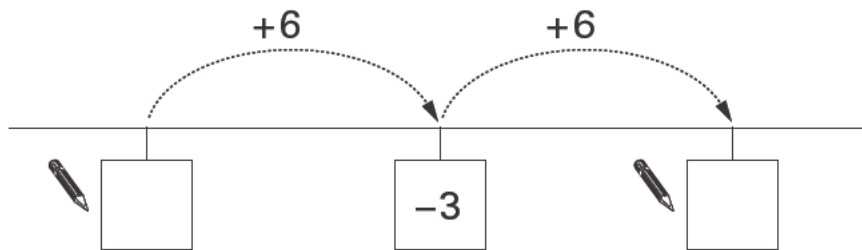

.....  
.....  
2 marks



2. Look at the diagrams on the centimetre square grid.  
Work out the **area** that is **shaded** on each diagram.

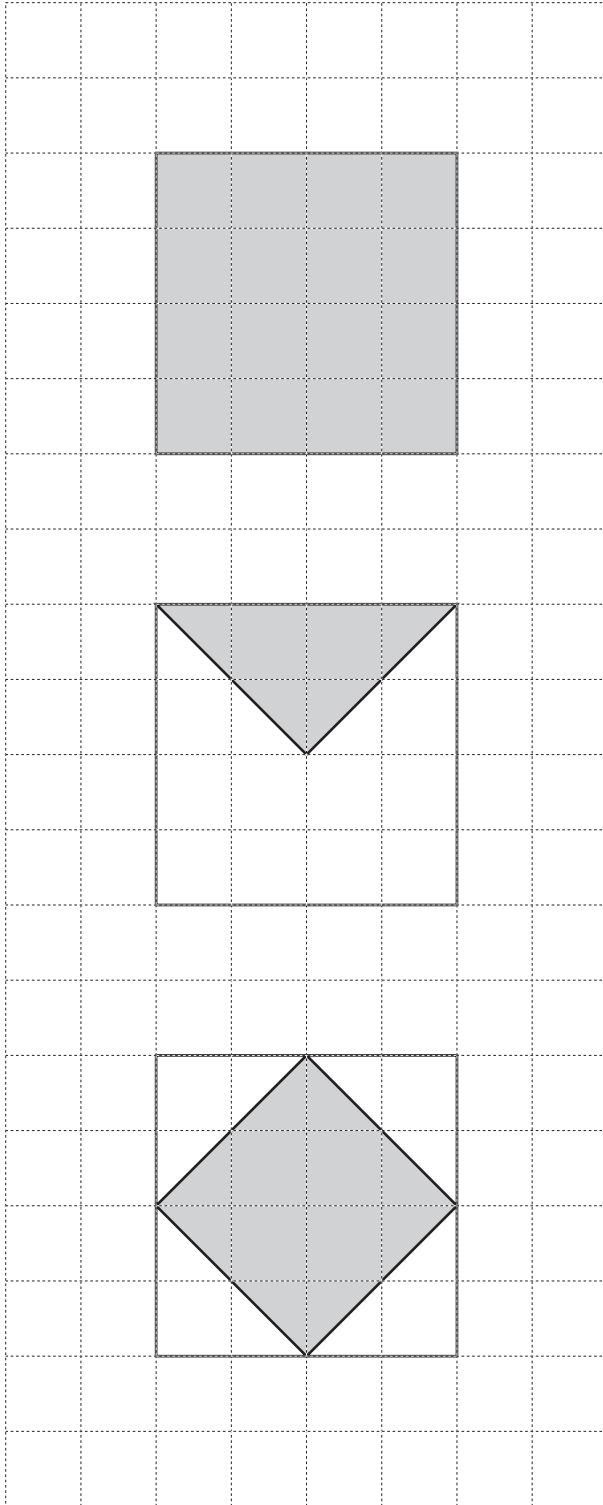

.....  $\text{cm}^2$



.....  $\text{cm}^2$



.....  $\text{cm}^2$

.....  
.....  
2 marks

3. (a) Add together **3.7** and **6.5**



.....

.....  
1 mark

(b) Subtract **5.7** from **15.2**



.....

.....  
1 mark

(c) Multiply **254** by **5**



.....

.....  
1 mark

(d) Divide **342** by **6**



.....

.....  
1 mark



4. (a) I weigh a melon.

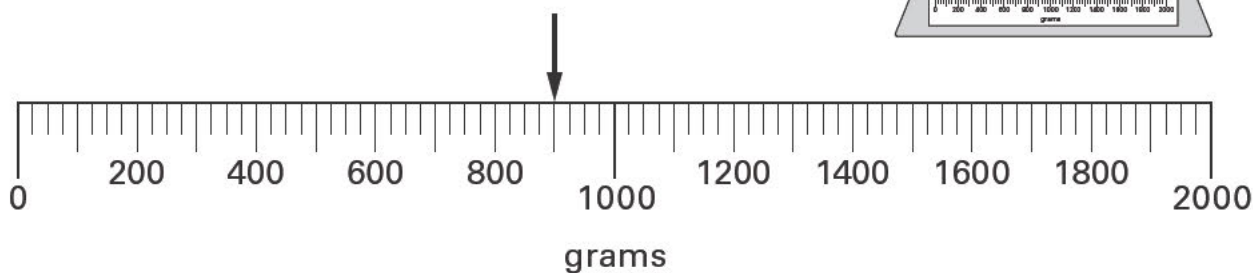
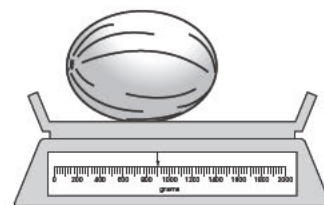

Then I weigh an apple and the melon.

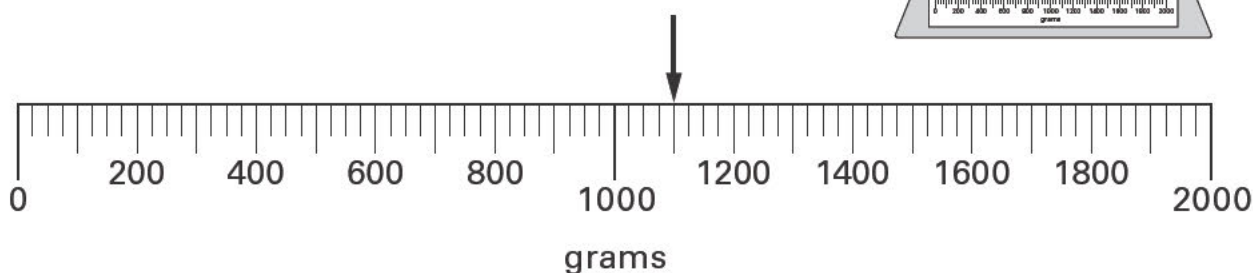
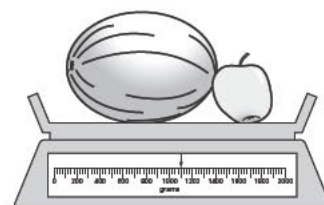

Write the missing numbers in the sentences below.



The **melon** weighs ..... grams.

.....  
1 mark

The **apple** weighs ..... grams.

.....  
1 mark

(b) **How many grams** are in one **kilogram**?

Put a ring round the correct number below.



1

10

100

1000

10 000

.....  
1 mark

5. (a) There are two children in the Smith family.  
The **range** of their ages is **exactly 7 years**.

What could the ages of the two children be?

Give an example.



..... and .....

.....  
1 mark

- (b) There are two children in the Patel family.  
They are twins of the **same age**.

What is the **range** of their ages?



..... years

.....  
1 mark



6. Here are four fractions.

$$\frac{3}{4}$$

$$\frac{1}{8}$$

$$\frac{1}{3}$$

$$\frac{3}{5}$$

Look at the number line below.

Write each fraction in the correct box.

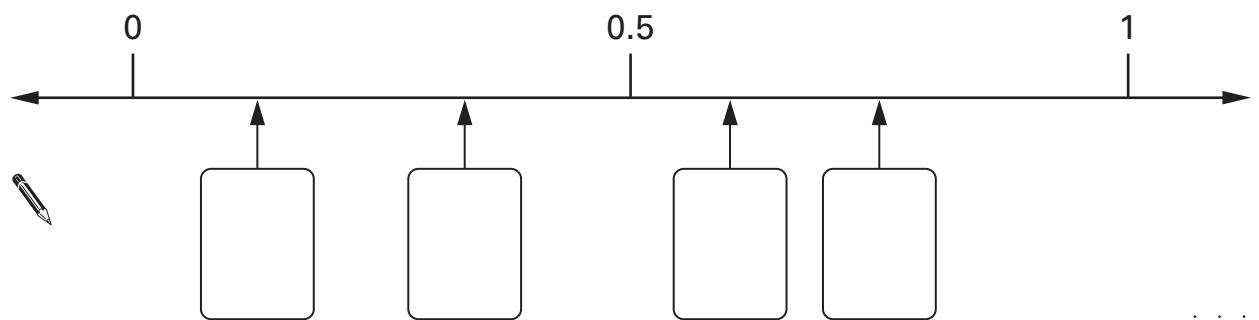

.....

.....

2 marks



7. (a) Jackie asked **27** people:

'Do you like school dinners?'

The bar chart shows her results for 'Yes' and 'No'.

Complete the bar chart to show her result for 'Don't know'.

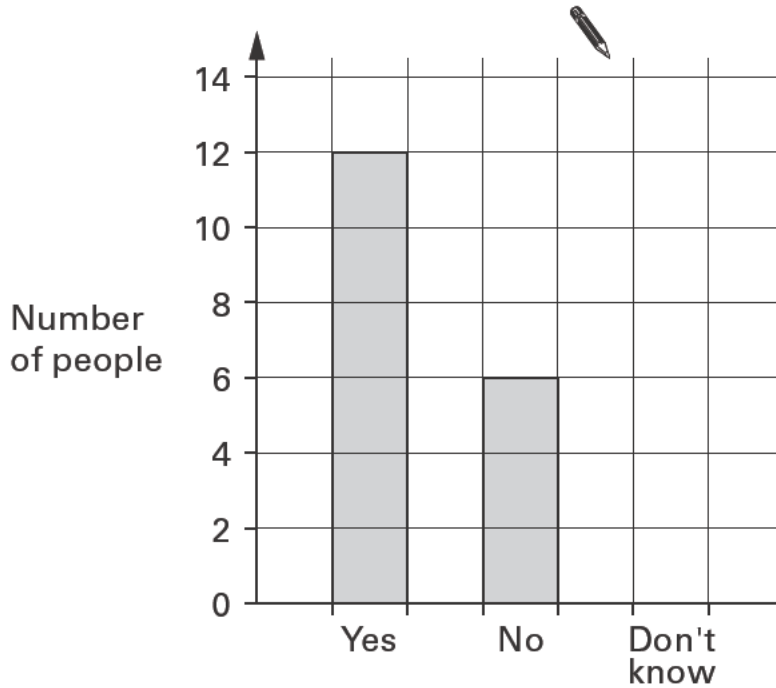

1 mark

(b) This pictogram also shows her results for 'Yes' and 'No'.

Complete the pictogram to show her result for 'Don't know'.

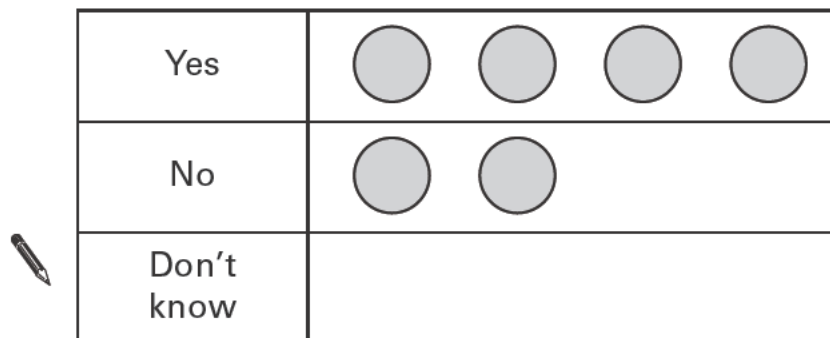

1 mark



8. (a) Complete the sentences.



..... **out of 10** is the same as **70%**

.....  
1 mark



**10 out of 20** is the same as .....%

.....  
1 mark

(b) Complete the sentence.



..... **out of** ..... is the same as **5%**

.....  
1 mark

Now complete the sentence using **different** numbers.



..... **out of** ..... is the same as **5%**

.....  
1 mark

9. The shapes below are drawn on square grids.  
 The diagrams show a rectangle that is rotated, then rotated again.  
 The centre of rotation is marked •

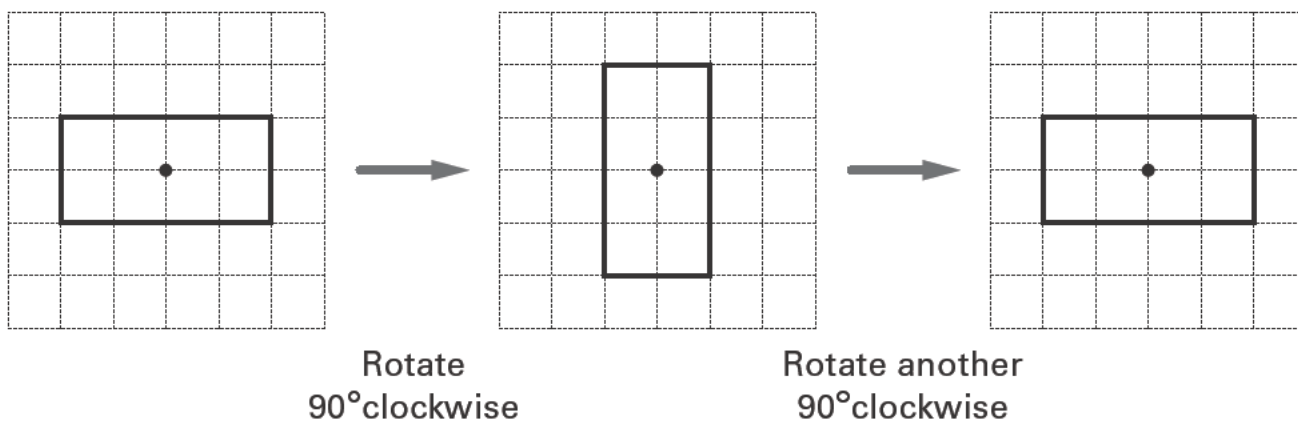

Complete the diagrams below to show the triangle when it is rotated,  
 then rotated again.

The centre of rotation is marked •

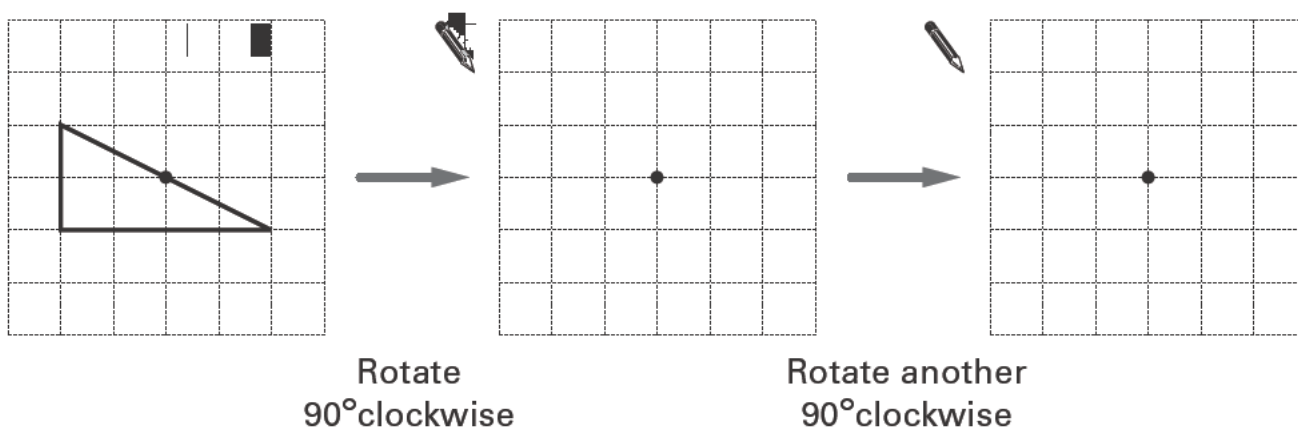

.....  
 .....  
 2 marks



10. I am thinking of a number.

My number **multiplied by 15** is **315**  
 My number **multiplied by 17** is **357**

What is my number?



.....  
 .....  
 2 marks

11. Complete the statements below.



When  $x$  is 8 ,  $4x$  is .....  
 1 mark

When  $x$  is ..... ,  $4x$  is 48 .....  
 1 mark

When  $x$  is 8 , ..... is 48 .....  
 1 mark

12. (a) Look at these three numbers.

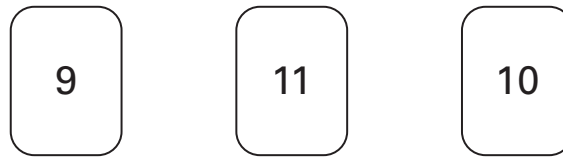

Show that the **mean** of the three numbers is **10**



1 mark

Explain why the **median** of the three numbers is **10**



1 mark

(b) Four numbers have a mean of 10 and a median of 10, but **none** of the numbers is 10

What could the four numbers be?

Give an example.



□      □      □      □

1 mark

13. The diagram shows triangle PQR.

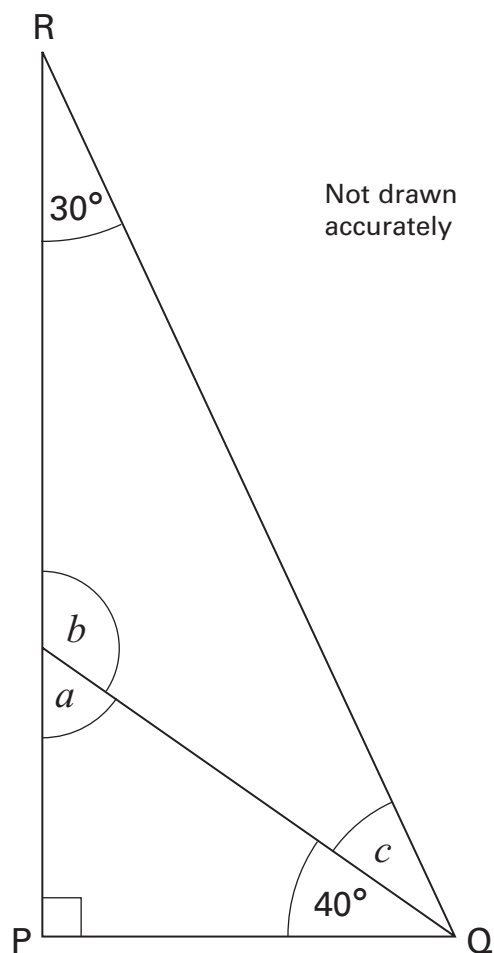

Work out the sizes of angles  $a$ ,  $b$  and  $c$



.....  
1 mark

.....  
1 mark

$$a = \text{.....}^\circ$$

$$b = \text{.....}^\circ$$

$$c = \text{.....}^\circ$$

.....  
1 mark

14. Solve these equations.

$$3y + 1 = 16$$



$$y = \dots\dots\dots$$

.....  
1 mark

$$18 = 4k + 6$$



$$k = \dots\dots\dots$$

.....  
1 mark

15. Work out

$$374 \times 23$$



.....

.....

.....  
2 marks



16. (a) P is the **midpoint** of line AB.

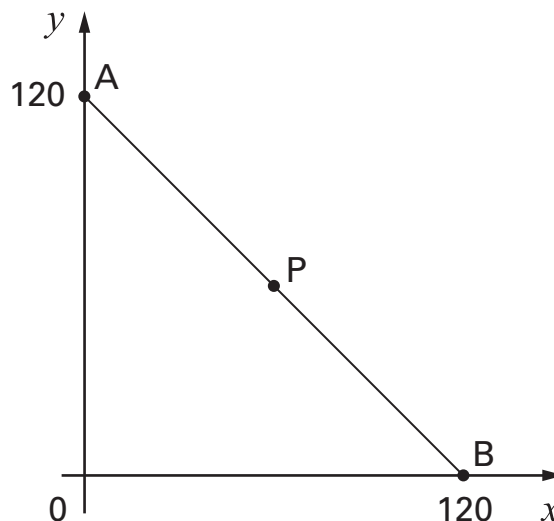

What are the coordinates of point P?



P is ( ..... , ..... )

.....  
1 mark

(b) Q is the **midpoint** of line MN.

The coordinates of Q are (30, 50)

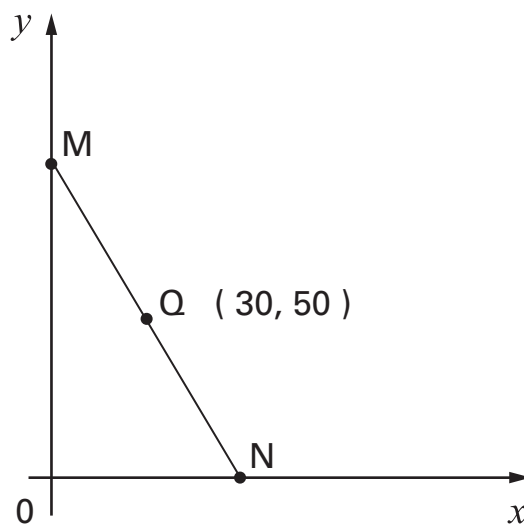

What are the coordinates of points M and N?



M is ( ..... , ..... )

.....  
1 mark

N is ( ..... , ..... )

.....  
1 mark



17. The diagram shows a **square**.  
 Two straight lines cut the square into four rectangles.  
 The area of one of the rectangles is shown.

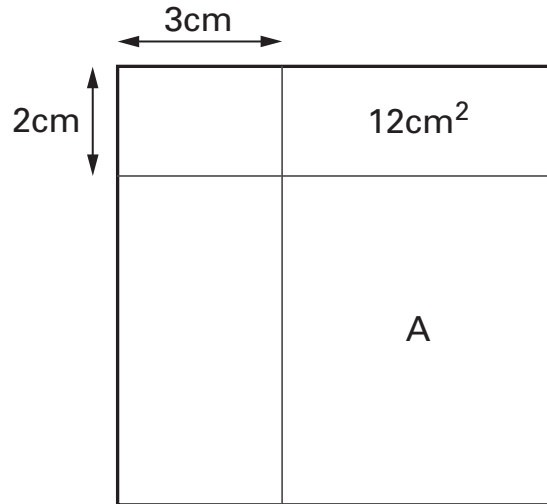

Not drawn accurately

Work out the area of the rectangle marked A.



..... cm<sup>2</sup>

.....  
 .....  
 2 marks



18. (a) Look at this information.

Two numbers **multiply** to make zero.

One of the statements below is true.

Tick (✓) the true statement.



- Both numbers must be zero.
- At least one number must be zero.
- Exactly one number must be zero.
- Neither number can be zero.

.....  
1 mark

(b) Now look at this information.

Two numbers **add** to make zero.

If **one** number is **zero**, what is the other number?



.....

.....  
1 mark

If **neither** number is **zero**, give an example of what the numbers could be.



..... and .....

.....  
1 mark

19. I join six cubes face to face to make each 3-D shape below.

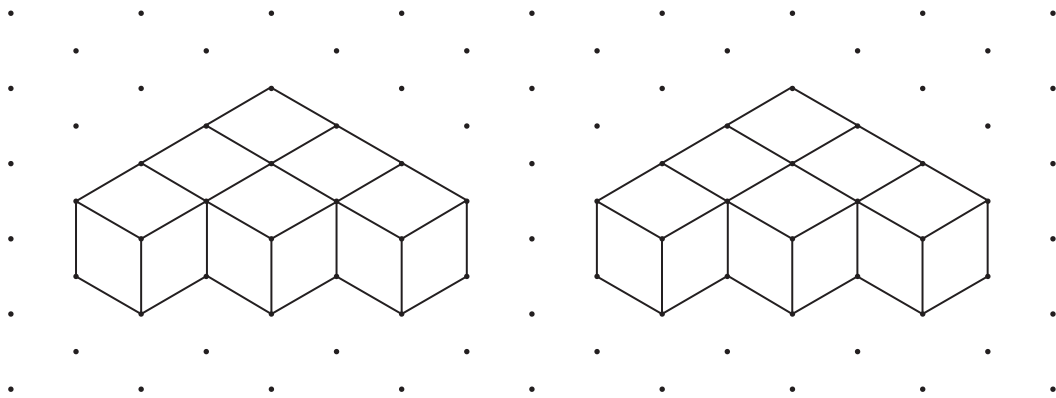

Isometric grid

Then I join the 3-D shapes to make a **cuboid**.

Draw this cuboid on the grid below.

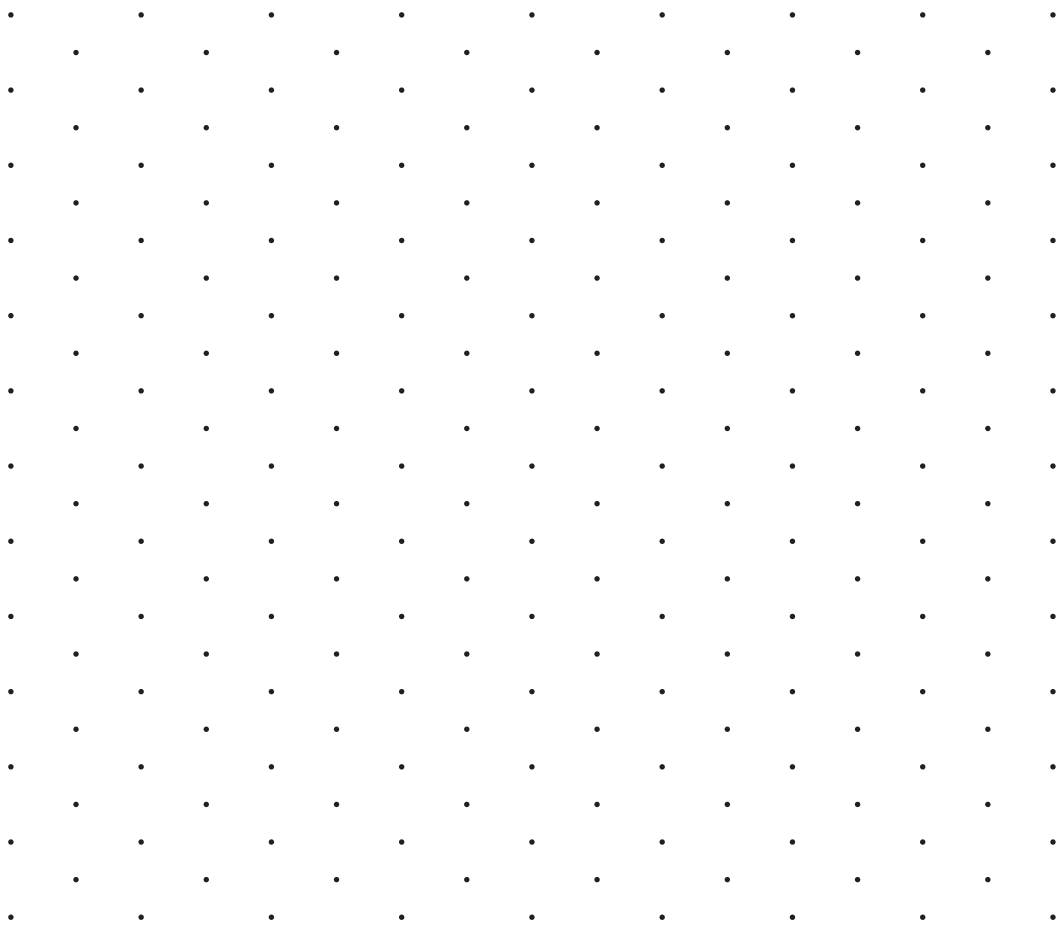

2 marks

Isometric grid



20. How many eighths are there in one quarter?



.....

Now work out  $\frac{3}{4} \div \frac{1}{8}$



.....

.....

.....

.....

3 marks

21. Solve this equation.

$$75 + 2t = 100 - 2t$$



.....

$t =$  .....

.....

2 marks

22. This shape has been made from two congruent **isosceles** triangles.

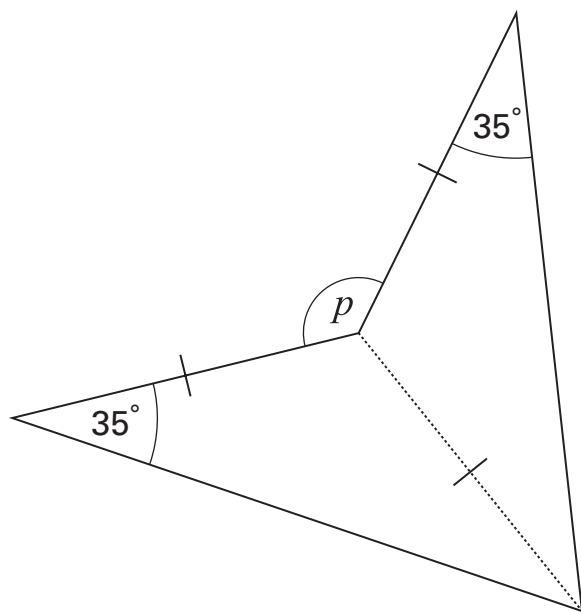

Not drawn accurately

What is the size of angle  $p$ ?



$p = \dots\dots\dots^\circ$

.....  
 .....  
 2 marks



23. Bumps are built on a road to slow cars down.

The stem-and-leaf diagrams show the speed of **15 cars** before and after the bumps were built.

**Key:**  
 2 | 3 means 23 mph

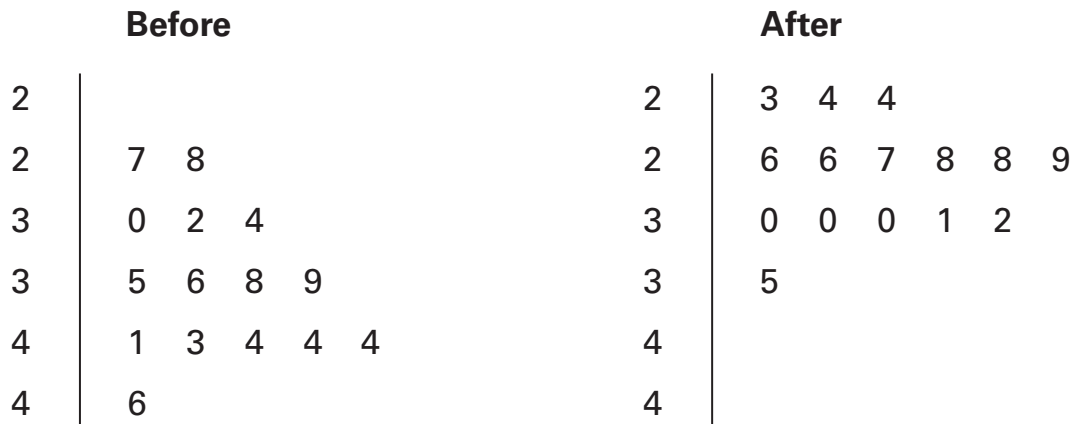

Use the diagrams to write the missing **numbers** in these sentences.



**Before** the bumps:

The maximum speed was ..... mph, and  
 ..... cars went at more than 30mph.

**After** the bumps:

The maximum speed was ..... mph, and  
 ..... cars went at more than 30mph.

.....  
 .....  
 2 marks

24. The graph shows the straight line with equation  $y = 3x - 4$

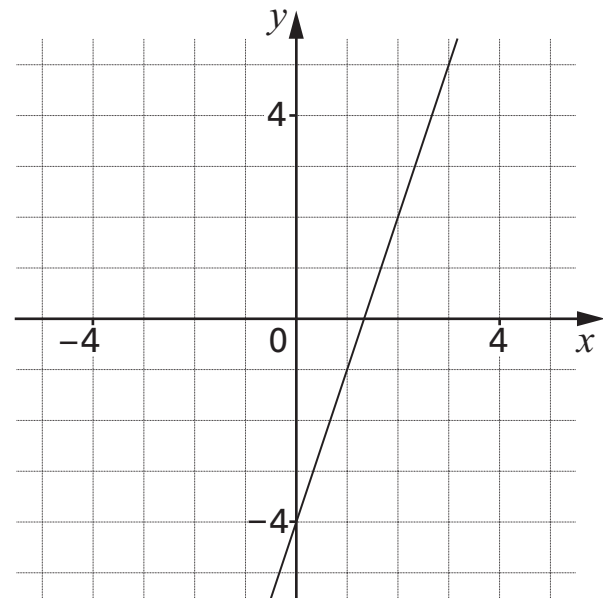

- (a) A point on the line  $y = 3x - 4$  has an  **$x$ -coordinate of 50**  
What is the  $y$ -coordinate of this point?



.....

.....  
1 mark

- (b) A point on the line  $y = 3x - 4$  has a  **$y$ -coordinate of 50**  
What is the  $x$ -coordinate of this point?



.....

.....  
1 mark

**END OF TEST**