

Ma

KEY STAGE

3

ALL TIERS

Mathematics tests

# Mark scheme

for Mental mathematics  
tests A, B and C

2009

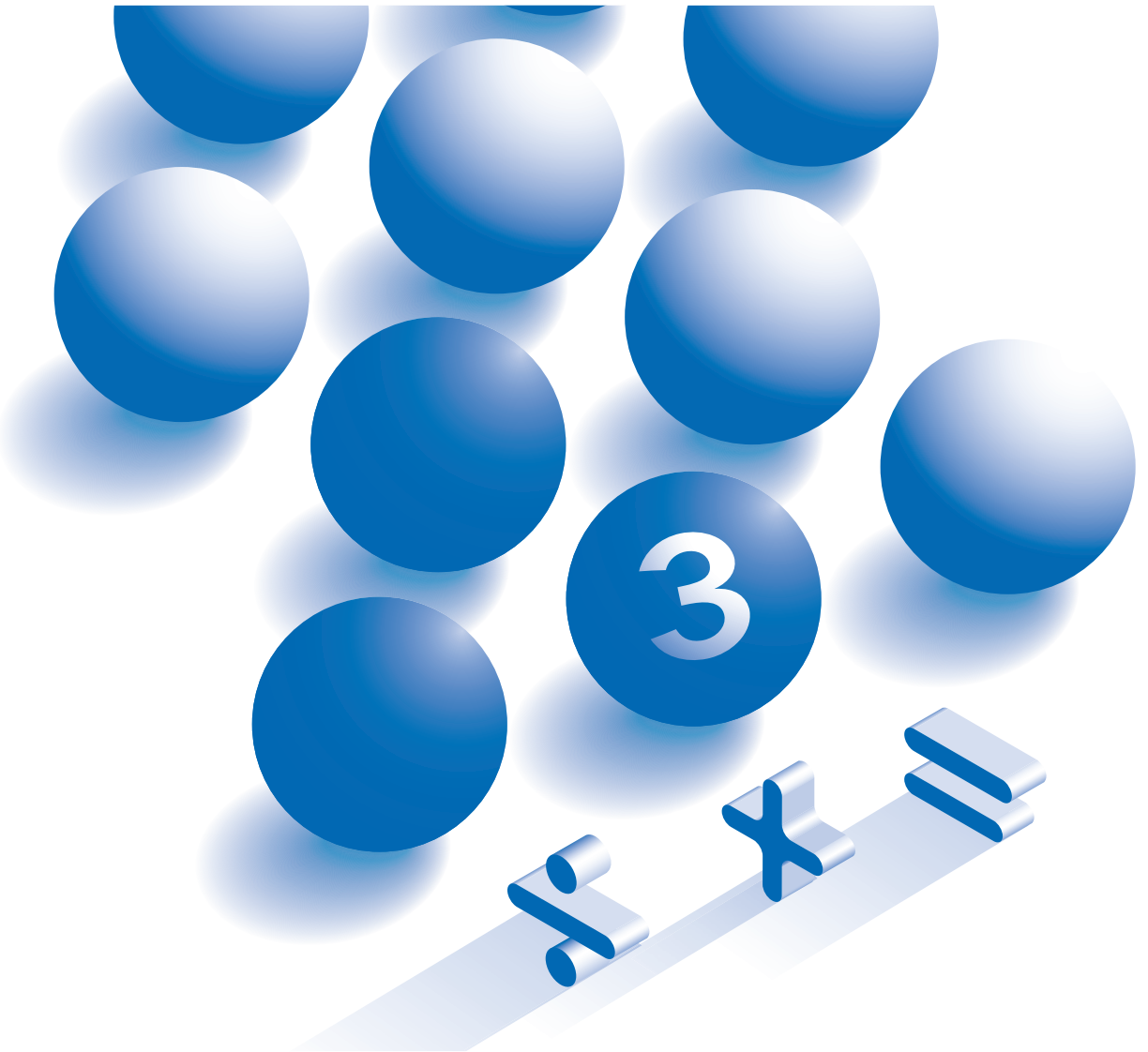

National curriculum assessments

QCA wishes to make its publications widely accessible.  
Please contact us if you have any specific accessibility requirements.

First published 2009

© Qualifications and Curriculum Authority 2009

ISBN 1-84721-699-1

Reproduction, storage, adaptation or translation, in any form or by any means, of this publication is prohibited without prior written permission of the publisher, unless within the terms of licences issued by the Copyright Licensing Agency. Excerpts may be reproduced for the purpose of research, private study, criticism or review, or by educational institutions solely for educational purposes, without permission, providing full acknowledgement is given.

Printed in Great Britain by the Qualifications and Curriculum Authority under the authority and superintendence of the Controller of Her Majesty's Stationery Office and Queen's Printer of Acts of Parliament.

The Qualifications and Curriculum Authority is an exempt charity under Schedule 2 of the Charities Act 1993.

Qualifications and Curriculum Authority  
83 Piccadilly  
London W1J 8QA  
[www.qca.org.uk](http://www.qca.org.uk)

# Introduction

This booklet contains the mark schemes for the lower tier test (test C) and the higher tiers tests (tests A and B).

## General guidance for markers

Please note that pupils should not be penalised if they record any information given in the question or show their working. Ignore any annotation, even if in the answer space, and mark only the answer. Accept an unambiguous answer written in the stimulus box, or elsewhere on the page, but clearly attributable to the relevant question.

General guidance for marking the written tests also applies to marking the mental mathematics tests. In addition, please apply the following principles unless specific instructions to the contrary are given in the mark scheme:

- accept responses in words and/or figures,  
eg 7 point 3, 4 hundred
- accept any unambiguous indication of the correct response from a given list,  
eg circling, ticking, underlining
- accept unambiguous misspellings
- accept units that have been correctly converted to a different unit provided the new unit is indicated. Where units have been given on the answer sheet, do not penalise pupils for writing the units again
- accept responses with commas as spacers,  
eg 50,000  
but do not accept a point used as a spacer,  
eg 50.000

## Lower tier test C questions

'Now we are ready to start the test.

For the first group of questions you will have 5 seconds to work out each answer and write it down.'

- 1 Write in figures the number eight hundred and one.
- 2 How many minutes are there in two hours?
- 3 What is twenty-six pounds fifty-eight pence rounded to the nearest pound?
- 4 What number do I need to add to sixty-three to make one hundred?
- 5 Multiply two hundred and six by ten.
- 6 How many faces does a triangular prism have?
- 7 I am thinking of a number. I call it  $b$ . I subtract two from my number. Write an expression to show the result.
- 8 Add eight to minus three.

'For the next group of questions you will have 10 seconds to work out each answer and write it down.'

- 9 The tally chart shows the number of silver and red cars a shop sold in one week. How many more red cars were sold than silver cars?
- 10 Look at the number line on your answer sheet. What number is the arrow pointing to?
- 11 A radio programme starts at six forty-five pm and lasts for forty-five minutes. At what time does the programme finish?
- 12 I am counting up in nought point twos. Two point three, two point five, two point seven, ... Write down the next two numbers.
- 13 Look at the number on your answer sheet. Round it to the nearest hundred.
- 14 The sequence of numbers on your answer sheet goes down in steps of four. Write the next two numbers in the sequence.
- 15 Look at the equation on your answer sheet. When  $a$  is thirty-four, what is the value of  $b$ ?
- 16 Look at the numbers on your answer sheet. Add them.

'Now turn over your answer sheet.'

## Pupil answer sheet

Key stage 3 mathematics 2009  
Mental mathematics Test C

First name \_\_\_\_\_

Last name \_\_\_\_\_

School \_\_\_\_\_

Total marks

Time: 5 seconds continued

8		-3	<input type="text"/>
---	--	----	----------------------

Time: 10 seconds

9	<table border="1"> <tr> <td>Silver</td> <td>     </td> <td>  </td> </tr> <tr> <td>Red</td> <td>     </td> <td>     </td> </tr> </table>	Silver			Red			<input type="text"/>
Silver								
Red								

10		<input type="text"/>
----	--	----------------------

11	6.45pm	45 minutes	<input type="text"/>
		pm	

12	2.3	2.5	2.7	<input type="text"/>

13		9343	<input type="text"/>
----	--	------	----------------------

14	16,	12,	8,	4	<input type="text"/>

15		$a - b = 14$	<input type="text"/>
----	--	--------------	----------------------

16		2.6	0.8	<input type="text"/>
----	--	-----	-----	----------------------

Practice question

	24	<input type="text"/>
--	----	----------------------

Time: 5 seconds

1	<input type="text"/>	<input type="text"/>
---	----------------------	----------------------

2	minutes	<input type="text"/>
---	---------	----------------------

3	£	£26.58	<input type="text"/>
---	---	--------	----------------------

4		63	<input type="text"/>
---	--	----	----------------------

5		206	<input type="text"/>
---	--	-----	----------------------

6		$b$	<input type="text"/>
---	--	-----	----------------------

7		$b$	<input type="text"/>
---	--	-----	----------------------

17	Look at the dial on your answer sheet. The arrow turns from 'off' to 'rinse'. Through how many degrees does the arrow turn?
18	One hundred people were asked whether they used a gym or not. The pie chart shows the results. How many people said no?
19	Halve the expression on your answer sheet.
20	Each side of a pentagon is eight centimetres long. What is its perimeter?
21	What is twenty per cent of fifty pounds?
<b>'For the next group of questions you will have 15 seconds to work out each answer and write it down.'</b>	
22	Look at the number machine on your answer sheet. I put in the number two. What number should come out?
23	Paul was born on the first of August in nineteen ninety-eight. How old will he be on the first of August in two thousand and nine?
24	Your answer sheet shows how Ella spent all her pocket money one month. What percentage did she spend on clothes?
25	Lisa did a survey to find out the type of books pupils in her class preferred. The bar chart shows her results. How many more pupils chose story books than poetry books?
26	Look at the shaded triangle drawn on a centimetre square grid. What is the area of the triangle?
27	Your answer sheet shows the coins Jack has in his pocket. He is going to take a coin from his pocket at random. What is the probability he will take a two pence coin?
28	Look at the names of shapes on your answer sheet. Put a ring round the name of the shape that has only one pair of parallel sides.
29	Four point three multiplied by six equals twenty-five point eight. What does four point three multiplied by twelve equal?
30	Look at the numbers on your answer sheet. Put a ring round the number that is prime.

**'Put your pens down. The test is finished.'**

**Time: 10 seconds continued**

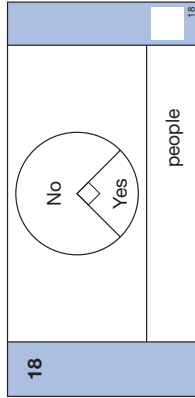
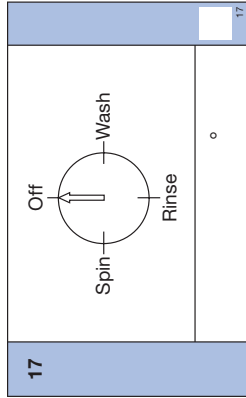

19

	$8pq$
--	-------

19

20

cm	8cm
----	-----

20

21

£	£.50
---	------

21

**Time: 15 seconds**

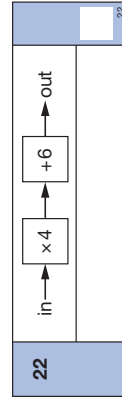

23

	2009
--	------

23

24

magazines	25%
food	40%
clothes	%

24

**Time: 15 seconds continued**

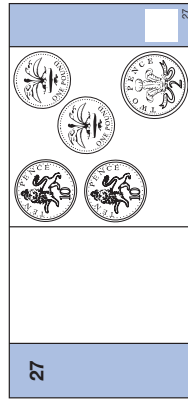
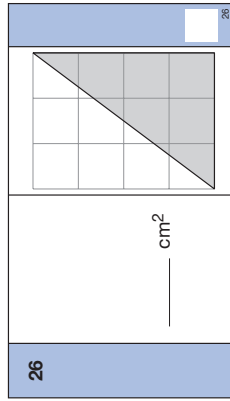
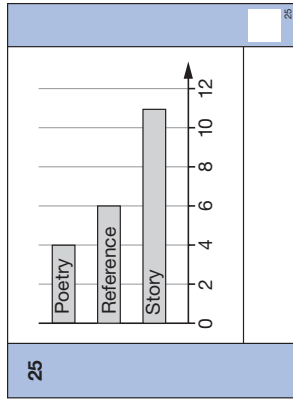

28

rectangle	rhombus
square	parallelogram
	trapezium

28

29

$4.3 \times 6 = 25.8$
-----------------------

29

30

21	23	25	27
----	----	----	----

30

# Test C

## Mark scheme

Time: 5 seconds

1	801	Do not accept responses given in words
2	120 minutes	
3	£ 27	Condone answers of £27.00
4	37	Accept embedded values, eg $63 + 37 = 100$
5	2060	
6	5	
7	$b - 2$	Do not accept unconventional notation, eg $1b - 2$

Time: 5 seconds continued

8	5	
---	---	--

Time: 10 seconds

9	6	
---	---	--

10	60	
----	----	--

11	7:30 pm	
----	---------	--

12	2.9 and 3.1	Accept pair in either order Accept equivalent fractions or decimals
----	-------------	--

13	9300	
----	------	--

14	0 and -4	Accept pair in either order
----	----------	-----------------------------

15	20	Accept embedded values, eg $34 - 20 = 14$
----	----	---

16	3.4	Accept equivalent fractions or decimals
----	-----	---

Time: 10 seconds continued

17	180 °	
----	-------	--

18	75	
----	----	--

19	$4pq$	Do not accept unconventional notation, eg $4 \times p \times q$
----	-------	---

20	40 cm	
----	-------	--

21	£ 10	
----	------	--

Time: 15 seconds

22	14	
----	----	--

23	11	
----	----	--

24	35 %	Do not accept equivalent fractions or decimals
----	------	--

Time: 15 seconds continued

25	7	
----	---	--

26	6 cm <sup>2</sup>	
----	-------------------	--

27	$\frac{1}{5}$	Accept equivalent probabilities
----	---------------	---------------------------------

28	rectangle	rhombus
	parallelogram	
	square	<b>trapezium</b>

29	51.6	Accept equivalent fractions or decimals
----	------	---

30	21	<b>23</b>	25	27
----	----	-----------	----	----

## Higher tiers test A questions

'Now we are ready to start the test.'

For the first group of questions you will have 5 seconds to work out each answer and write it down.'

- 1 How many metres are six hundred centimetres?
- 2 Subtract thirty-six from two hundred.
- 3 Write in figures the number ten thousand and ten.
- 4 Look at the numbers on your answer sheet. Add them.
- 5 Look at the number on your answer sheet. Round it to two decimal places.
- 6 Look at the expression. Write it as simply as possible.
- 7 To the nearest centimetre the length of a shelf is fifty-eight centimetres. What is the smallest value the length of the shelf could be?

'For the next group of questions you will have 10 seconds to work out each answer and write it down.'

- 8 Look at the equation. What is the value of  $x$ ?
- 9 I started a train journey at three twenty pm. The journey lasted for forty-five minutes. At what time did I arrive?
- 10 Some pupils were asked how they had travelled to school that day. The pie chart shows the results. Which form of transport is the mode?
- 11 What is fifty per cent of one hundred and ten pounds?
- 12 Write down a multiple of four that is greater than one thousand.
- 13 Draw an arrow on the scale to show two point two kilograms.
- 14 A football team won fifty-five per cent of their games and lost thirty per cent. The rest ended in a draw. What percentage of their games ended in a draw?

'Now turn over your answer sheet.'

- 15 On my desk I have three blue pens, one red pen and four black pens. I am going to pick up one of the pens at random. What is the probability that I will pick up a black pen?

## Pupil answer sheet

Key stage 3 mathematics 2009  
Mental mathematics Test A

First name \_\_\_\_\_

Last name \_\_\_\_\_

School \_\_\_\_\_

Total marks

Time: 5 seconds continued

6	<input type="text"/>	$8p^2 - p^2$	<input type="text"/>
7	<input type="text"/>	cm	58cm

Time: 10 seconds

8	<input type="text"/>	$x + 7 = 22$	<input type="text"/>
9	<input type="text"/>	pm	45 minutes

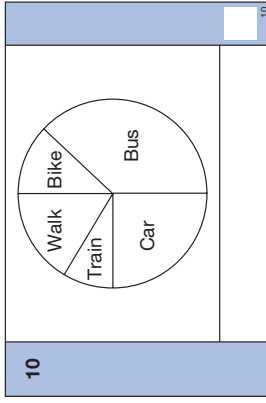

11	£	50%	<input type="text"/>
----	---	-----	----------------------

12	<input type="text"/>	<input type="text"/>
----	----------------------	----------------------

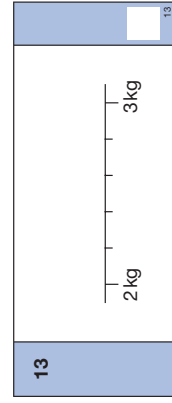

14	<input type="text"/>	%	won 55%	<input type="text"/>
	<input type="text"/>		lost 30%	<input type="text"/>

Practice question

<input type="text"/>	<input type="text"/>	39	<input type="text"/>
----------------------	----------------------	----	----------------------

Time: 5 seconds

1	m	600cm	<input type="text"/>
2	<input type="text"/>	36	<input type="text"/>
3	<input type="text"/>	<input type="text"/>	<input type="text"/>
4	<input type="text"/>	-9	5
5	<input type="text"/>	0.576	<input type="text"/>



- 16 A rectangular football pitch is sixty-five metres by one hundred metres. A footballer runs once around the perimeter of the pitch. How far does he run?
- 17 Write down a prime number between ten and twenty.
- 18 Look at the expression.  
When  $m$  is eight, what is the value of the expression?
- 19 There are ninety seats in a train carriage.  
How many seats are there in twelve of these carriages?
- 20 Your answer sheet shows a diagram of a 3-D shape.  
What is the mathematical name of this shape?
- 21 Twelve people in a group are left-handed.  
Twenty per cent of the group are left-handed.  
How many people are in the group?
- 22 A bird flies at an average speed of thirty-six kilometres per hour.  
At this speed, how far would it fly in ten minutes?
- 23 Look at the equation.  
What is the value of  $y$  when  $x$  equals three?
- 24 What is the square root of one ninth?

*'For the next group of questions you will have 15 seconds to work out each answer and write it down.'*

- 25 I eat one half of a pizza.  
My friend eats one third of the pizza. What fraction of the pizza is left?
- 26 Look at the regular decagon. The exterior angle marked  $a$  is thirty-six degrees.  
What is the size of an interior angle?
- 27 I can make a three-digit number using the digits one, two and three in six different ways. How many of these three-digit numbers are even?
- 28 The mean of three numbers is ten. Two of the numbers are eight.  
What is the third number?
- 29 The diagram shows three lines meeting at a point.  
Work out the value of  $k$ .
- 30 Write down the three consecutive whole numbers that add up to forty-five.

*'Put your pens down. The test is finished.'*

Time: 10 seconds continued

15	3 blue, 1 red, 4 black	15
----	------------------------	----

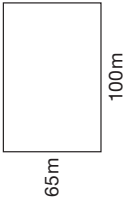
16	 65m                      100m	16
----	--	----

17	10    20	17
----	----------	----

18	$4(m-3)$	18
----	----------	----

19	90    12	19
----	----------	----

20		20
----	---	----

21	people    12    20%	21
----	---------------------	----

22	36 km per hour	22
	km	

23	$y = 4x^2$	23
----	------------	----

Time: 10 seconds continued

24	$\sqrt{\frac{1}{9}}$	24
----	----------------------	----

Time: 15 seconds

25	$\frac{1}{2} - \frac{1}{3}$	25
----	-----------------------------	----

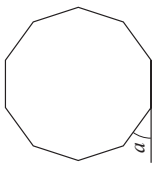
26	 $a^\circ$	26
----	--	----

27	1    2    3	27
----	-------------	----

28	Mean = 10	28
----	-----------	----

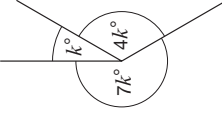
29		29
----	--	----

30	____, ____, ____	45	30
----	------------------	----	----

# Test A

## Mark scheme

Time: 5 seconds

1	6 m	Do not accept amended units
2	164	
3	10 010	
4	-4	
5	0.58	Do not accept equivalent fractions or decimals

Time: 5 seconds continued

6	$7p^2$	Do not accept unconventional notation, eg $7 \times p^2$ or $7pp$
7	57.5 cm	Accept equivalent fractions or decimals

Time: 10 seconds

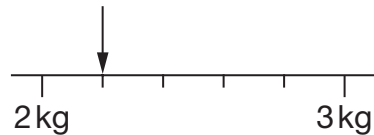
8	15	Accept embedded values, eg $15 + 7 = 22$
9	4:05 pm	
10	Bus	Accept unambiguous indication, eg Bu
11	£ 55	
12	Any multiple of 4 greater than 1000, eg 1004, 5064	Note that any number is a multiple of 4 where the last two digits constitute a number that is a multiple of four
13	2.2kg marked on the scale, ie	
14	15 %	Do not accept equivalent fractions or decimals

**Time: 10 seconds continued**

15	$\frac{1}{2}$	Accept equivalent probabilities
----	---------------	---------------------------------

16	330 m	
----	-------	--

17	One of 11, 13, 17 or 19	
----	-------------------------	--

18	20	
----	----	--

19	1080	
----	------	--

20	cylinder	Accept 'circular prism'
----	----------	-------------------------

21	60 people	
----	-----------	--

22	6 km	
----	------	--

23	36	
----	----	--

**Time: 10 seconds continued**

24	$\frac{1}{3}$	Accept $-\frac{1}{3}$ with $\frac{1}{3}$ or alone Accept 0.33 or better
----	---------------	--

**Time: 15 seconds**

25	$\frac{1}{6}$	Accept equivalent fractions Do not accept equivalent decimals
----	---------------	--

26	144 °	
----	-------	--

27	2	Accept both even numbers given, ie 132 and 312
----	---	--

28	14	
----	----	--

29	30	Accept 30°
----	----	------------

30	14, 15, 16	Accept values in any order
----	------------	----------------------------

## Higher tiers test B questions

'Now we are ready to start the test.'

For the first group of questions you will have 5 seconds to work out each answer and write it down.'

- 1 Look at the units of length on your answer sheet.  
Put a ring round the one that is best used for the distance between two towns.
- 2 Look at the expression.  
Write it as simply as possible.
- 3 Write the number that is three less than six thousand.
- 4 Multiply seven point eight by two.
- 5 What number is three cubed?
- 6 The probability that I will have toast for breakfast is nought point three.  
What is the probability that I will not have toast for breakfast?
- 7 Write nought point nought nine as a fraction.
- 8 Multiply minus six by minus eight.

'For the next group of questions you will have 10 seconds to work out each answer and write it down.'

- 9 A carton of orange drink costs twenty-five pence.  
How many cartons can I buy for two pounds fifty?
- 10 I was delayed in traffic from quarter to six to twenty past six one evening.  
For how many minutes was I delayed?
- 11 Look at the numbers on your answer sheet. Add them.
- 12 Pupils in a class were asked if they would prefer an apple or a banana.  
The pictogram shows the results. How many pupils were in the class?
- 13 At ten pm, the temperature was eight degrees Celsius.  
By midnight the temperature had dropped by ten degrees.  
What was the temperature at midnight?
- 14 Look at the rectangle drawn on a square grid.  
What percentage of the rectangle is shaded?
- 15 Put a cross on the grid to show the point with coordinates minus two, one.

'Now turn over your answer sheet.'

## Pupil answer sheet

Key stage 3 mathematics 2009

Mental mathematics Test B

First name \_\_\_\_\_

Last name \_\_\_\_\_

School \_\_\_\_\_

Total marks

Time: 5 seconds continued

7		0.09	<input type="text"/>
---	--	------	----------------------

8			<input type="text"/>
---	--	--	----------------------

Time: 10 seconds

9		25p	£2.50	<input type="text"/>
---	--	-----	-------	----------------------

10	Quarter to six	<input type="text"/>
	minutes	<input type="text"/>

11	13	14	15	<input type="text"/>
----	----	----	----	----------------------

12	Key: $\bigcirc = 3$ pupils	<input type="text"/>										
	<table border="1"> <tr> <td>Apple</td> <td><math>\bigcirc</math></td> <td><math>\bigcirc</math></td> <td><math>\bigcirc</math></td> <td><math>\bigcirc</math></td> </tr> <tr> <td>Banana</td> <td><math>\bigcirc</math></td> <td><math>\bigcirc</math></td> <td><math>\bigcirc</math></td> <td><math>\bigcirc</math></td> </tr> </table>	Apple	$\bigcirc$	$\bigcirc$	$\bigcirc$	$\bigcirc$	Banana	$\bigcirc$	$\bigcirc$	$\bigcirc$	$\bigcirc$	pupils
Apple	$\bigcirc$	$\bigcirc$	$\bigcirc$	$\bigcirc$								
Banana	$\bigcirc$	$\bigcirc$	$\bigcirc$	$\bigcirc$								

13	$^{\circ}\text{C}$	$8^{\circ}\text{C}$	<input type="text"/>
----	--------------------	---------------------	----------------------

14	%	<table border="1"><tr><td></td><td></td></tr><tr><td></td><td></td></tr></table>					<input type="text"/>

15		<input type="text"/>
----	--	----------------------

Practice question

	39	<input type="text"/>
--	----	----------------------

Time: 5 seconds

1	millimetres	kilometres	<input type="text"/>
	metres	inches	<input type="text"/>
	centimetres		<input type="text"/>

2	$8y + 3y$	<input type="text"/>
---	-----------	----------------------

3	6000	<input type="text"/>
---	------	----------------------

4	7.8	<input type="text"/>
---	-----	----------------------

5		<input type="text"/>
---	--	----------------------

6	0.3	<input type="text"/>
---	-----	----------------------

- 16 A teacher asked pupils in a class 'Do you have a pet?' The percentage bar chart shows the results. Estimate the percentage of pupils who said no.
- 17 A regular pentagon has a side length of four centimetres. What is its perimeter?
- 18 Look at the isosceles triangle. What is the size of angle  $x$ ?
- 19 On a sponsored walk, I walked four miles in each hour. How long did it take me to walk eighteen miles?
- 20 The prices of meals in a canteen are increased by five per cent. What is the new price if the old price was two pounds?
- 21 Look at the equation. What is the value of  $x$  when  $y$  is twenty?
- 22 A rectangular photograph measures eight centimetres by ten centimetres. I enlarge the photograph so that the shorter side is twelve centimetres. What is the length of the longer side?
- 23 Look at the expression. Multiply out the brackets.

**'For the next group of questions you will have 15 seconds to work out each answer and write it down.'**

- 24 I am thinking of two numbers that add to twelve. One number is two more than the other. What are my two numbers?
- 25 The scale of a map is one centimetre to two kilometres. On the map two places are seven and a half centimetres apart. What is the actual distance between the two places?
- 26 One hundred pupils study French, German or both languages. Sixty-five pupils study French and eighty-three pupils study German. How many study both languages?
- 27 Look at the expression. When  $b$  is seven, work out the value of the expression.
- 28 The table shows the number of children in ten families. How many children are there altogether?
- 29 The angles in a triangle are in the ratio two to three to four. What are the sizes of the three angles?
- 30 The diagram shows a right-angled triangle. Which value under the triangle shows the length of the hypotenuse? Put a ring round the correct value.

**'Put your pens down. The test is finished.'**

**Time: 10 seconds continued**

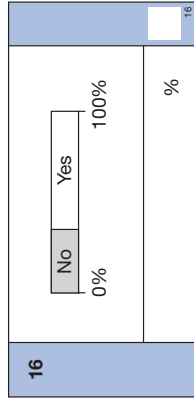

17

cm	4cm
----	-----

17

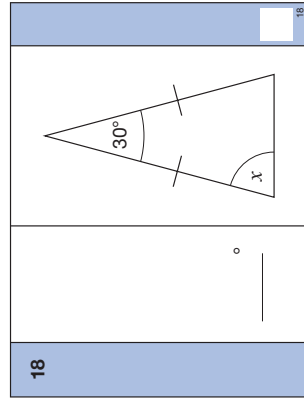

19

hours	18
-------	----

19

20

£	5%	£2
---	----	----

20

21

	$y = 3x - 7$
--	--------------

21

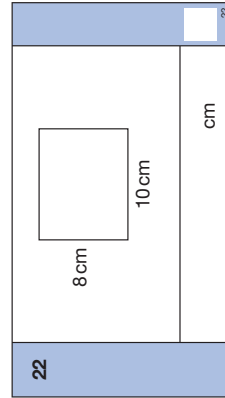

23

	$3y(5 - y)$
--	-------------

23

**Time: 15 seconds**

24 \_\_\_\_\_ and \_\_\_\_\_

24

25 1cm : 2km  $7\frac{1}{2}$  cm  
\_\_\_\_\_ km

25

26 \_\_\_\_\_ 65 83

26

27 \_\_\_\_\_  $(3 + b)^2$   
\_\_\_\_\_ 5

27

28

Number of children	Frequency
0	1
1	1
2	4
3	3
4	1

children

28

29 \_\_\_\_\_ 2 : 3 : 4  
\_\_\_\_\_ , \_\_\_\_\_ , \_\_\_\_\_ °

29

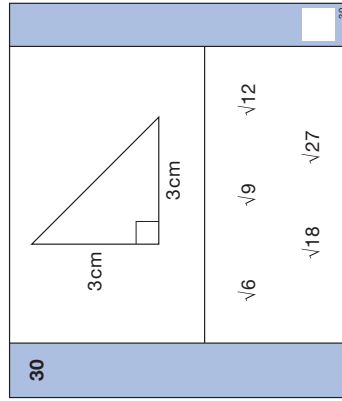

# Test B

## Mark scheme

Time: 5 seconds

1	millimetres <b>kilometres</b> metres centimetres      inches
---	--

2	<b>11y</b>	Do not accept unconventional notation, eg $11 \times y$
---	------------	---

3	<b>5997</b>	
---	-------------	--

4	<b>15.6</b>	Accept equivalent fractions or decimals
---	-------------	---

5	<b>27</b>	
---	-----------	--

6	<b>0.7</b>	Accept equivalent probabilities
---	------------	---------------------------------

Time: 5 seconds continued

7	$\frac{9}{100}$	Accept equivalent decimals Do not accept equivalent fractions
---	-----------------	--

8	<b>48</b>	
---	-----------	--

Time: 10 seconds

9	<b>10</b>	
---	-----------	--

10	<b>35</b> minutes	
----	-------------------	--

11	<b>42</b>	
----	-----------	--

12	<b>21</b> pupils	
----	------------------	--

13	<b>-2 °C</b>	
----	--------------	--

14	<b>75 %</b>	Do not accept equivalent fractions or decimals
----	-------------	--

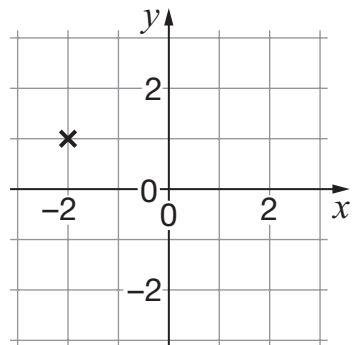
15		
----	---	--

Time: 10 seconds continued

16	30 % ≤ answer ≤ 40 %	
	Do not accept equivalent fractions or decimals	
17	20 cm	
18	75 °	
19	4 $\frac{1}{2}$ hours	Accept equivalent fractions or decimals Accept 4 hours 30 minutes
20	£ 2.10	
21	9	
22	15 cm	
23	15y - 3y <sup>2</sup>	Accept unconventional notation, eg 15 × y - 3y × y Do not accept incomplete processing, eg 5 × 3y - 3y <sup>2</sup>

Time: 15 seconds

24	5 and 7	Accept pair in either order
25	15 km	
26	48	
27	20	
28	22 children	
29	40 °, 60 °, 80 °	
	Accept values in any order	
30	√6      √9      √12	
	<div style="text-align: center;"> <span style="border: 1px solid black; border-radius: 50%; padding: 2px 10px;">√18</span>                      <span>√27</span> </div>	



# National Assessment Agency

29 Bolton Street  
London W1J 8BT

Telephone: 08700 60 60 40  
Minicom: 020 7509 6546  
Fax: 020 7509 5908

Email: [tests@naa.org.uk](mailto:tests@naa.org.uk)  
Website: [www.naa.org.uk/tests](http://www.naa.org.uk/tests)



Qualifications and  
Curriculum Authority  
Sourced from SATs Papers.co.uk

**For more copies:**

QCA Orderline, PO Box 29, Norwich NR3 1GN  
[www.qca.org.uk/orderline](http://www.qca.org.uk/orderline) email: [orderline@qca.org.uk](mailto:orderline@qca.org.uk)  
Tel: 08700 60 60 15 Fax: 08700 60 60 17

QCA/09/3783

<https://www.SATs-Papers.co.uk> 290026