

Year 8

Mathematics

Foundation: No calculator allowed

Time allowed: 45 minutes

First name						
Middle name						
Last name						
Date of birth	Day		Month		Year	
Teacher						

These assessments have been designed by White Rose Maths.
For more information, please visit www.whiterosemaths.com

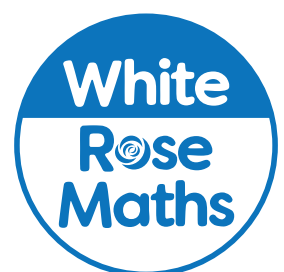

1

Plot the point (4, 3) on the grid shown.

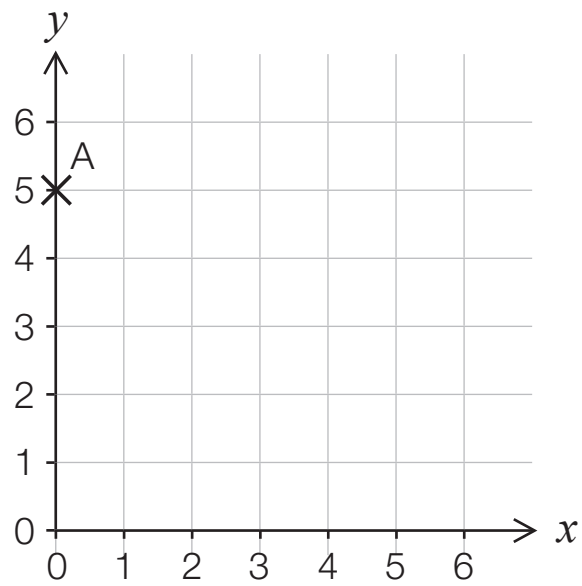

1 mark

What are the coordinates of point A?

(,)

1 mark

2

One quarter of a number is 10

What is the number?

You may use the diagram to help you.

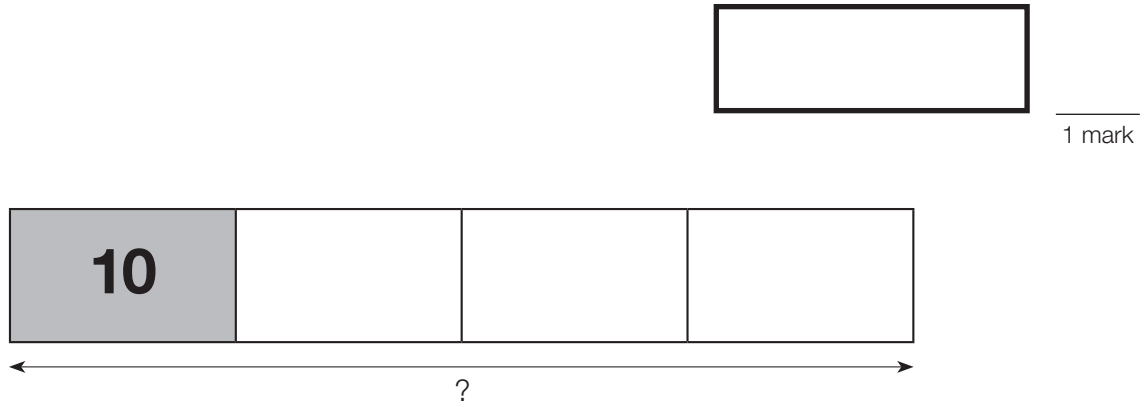
**3**

Work out

$$\frac{1}{3} + \frac{1}{3} = \boxed{\frac{\quad}{\quad}}$$

1 mark

$$\frac{1}{3} \times \frac{1}{3} = \boxed{\frac{\quad}{\quad}}$$

1 mark

4

Write the following ratios in their simplest form.

12 : 4

1 mark

30 : 50 : 40

1 mark

Fill in the missing number.

2 : 3 is equivalent to 14 :

1 mark

5

The diagram shows the scale drawing of a bridge.

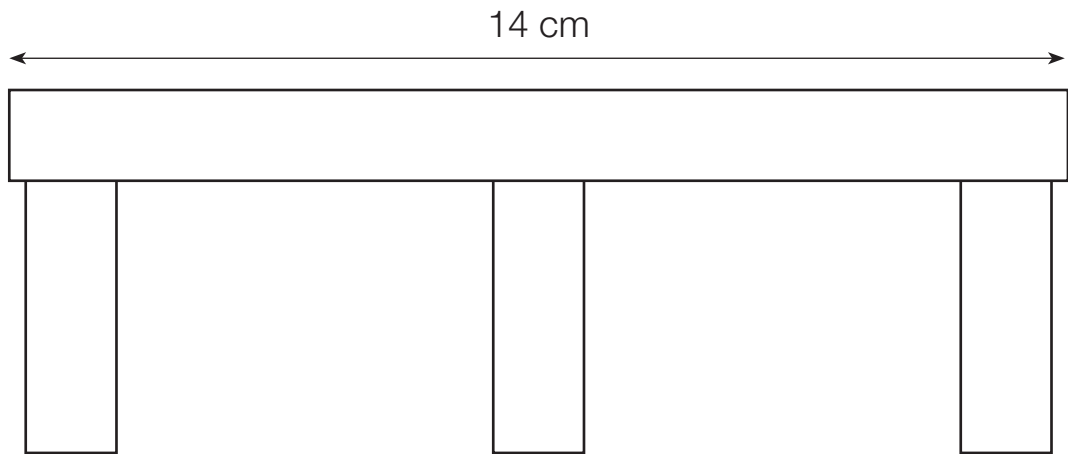

Scale 1 cm represents 3 m

Work out the real length of the bridge in metres.

1 mark

The real length of another bridge is 18 m.

This bridge is drawn to the same scale.

Work out the length of this bridge on the scale diagram.

1 mark

6

The point (4, 8) lies on the line $y = 2x$

Complete the coordinates for two other points that lie on this line.

(5,)

(, -6)

2 marks

7

Adam and Zak share £35 in the ratio 1 : 4

How much does each person receive?

You may use the diagram at the bottom of the page to help you.

Adam

£

Zak

£

2 marks

Adam

Zak

--	--	--	--

8

This number line shows the calculation $4 \times \frac{2}{3}$

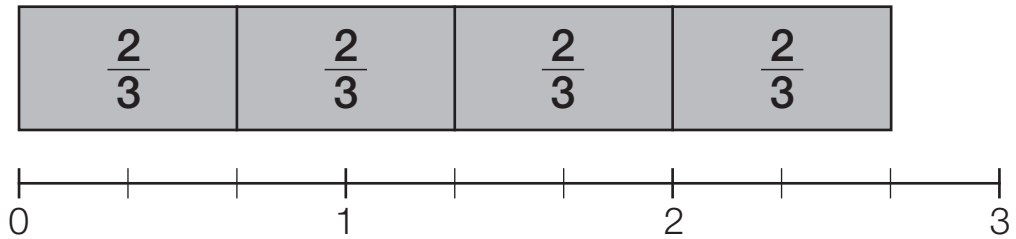

Complete the calculation.

$$4 \times \frac{2}{3} = \frac{\square}{3} = \square \frac{\square}{3}$$

1 mark

You may use the number lines to help you in the remaining parts of this question.

Work out $3 \times \frac{3}{4}$

Give your answer as a mixed number.

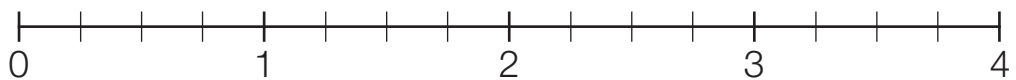

2 marks

Work out $4 \div \frac{1}{3}$

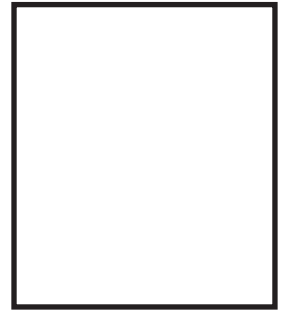
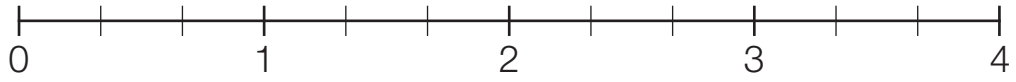

1 mark

Work out $4 \div \frac{2}{3}$

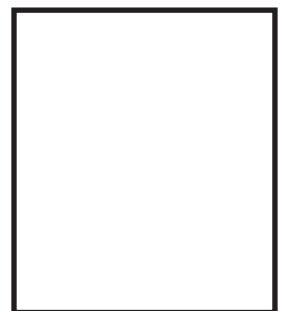
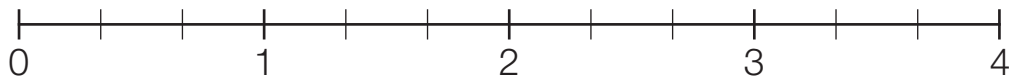

1 mark

9

The shoe sizes of 12 children are shown.

Use the data to complete the table.

5 5 7 5 8 5
7 8 7 5 8 7

Shoe size	Tally	Frequency
5		
6		
7		
8		

2 marks

10

A bag contains 3 red, 2 blue and 4 green counters.

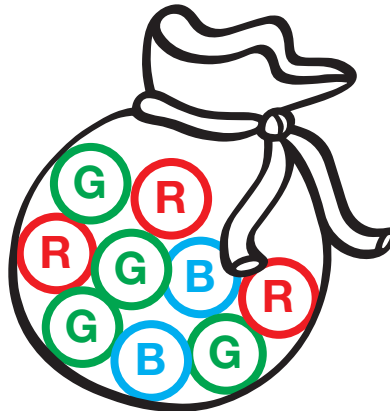

I pick a counter from the bag without looking.

What is the probability the counter is blue?

_____ 1 mark

What is the probability the counter is not red?

_____ 1 mark

What is the ratio of the number of green counters to the number of blue counters in the bag?

Give your answer in its simplest form.

_____ 1 mark

11

These two triangles are similar.

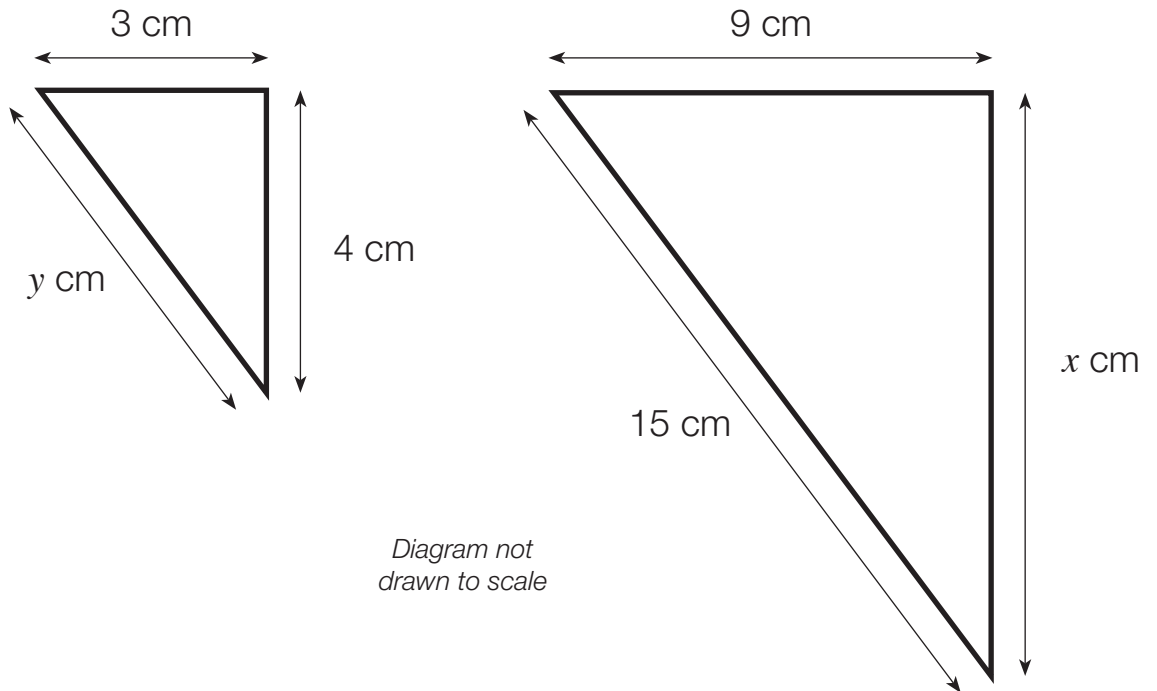

Work out the length of the side labelled x .

cm

1 mark

Work out the length of the side labelled y .

cm

1 mark

12

Dexter did a survey of the number of cold drinks some pupils in his school drank yesterday.

Number	Frequency
2	4
3	3
4	5
5	8
6	4

How many pupils were asked altogether?

1 mark

How many pupils drank fewer than 4 drinks?

1 mark

13

This is a conversion graph between miles and kilometres.

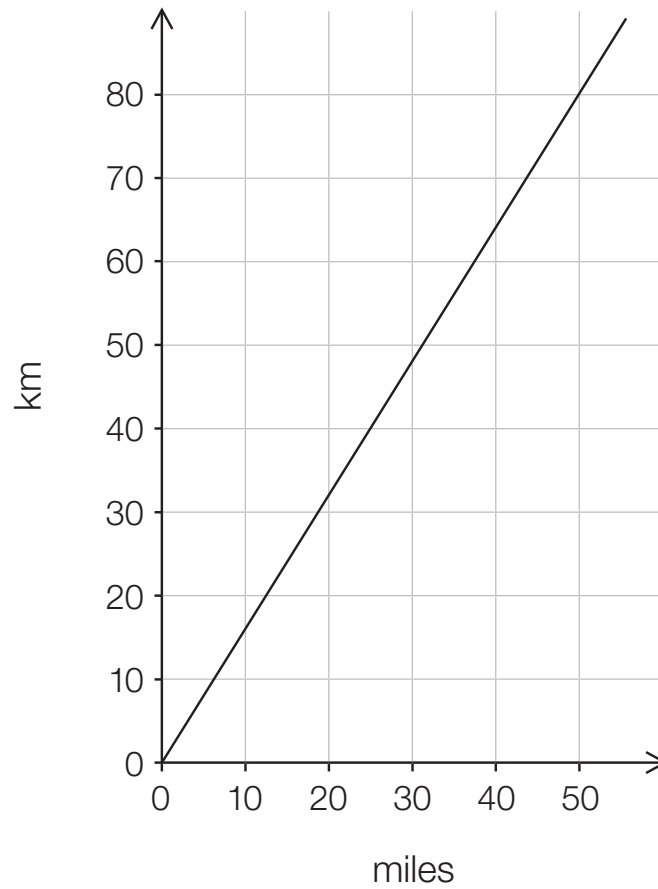

Use the graph to answer the questions.

How many km is the same as 50 miles?

1 mark

How many miles is the same as 70 km?

1 mark

14

The table shows how 100 children travelled to school.

Complete the two-way table.

	Walk	Bus	Total
Boys	27		
Girls	13		54
Total		60	100

2 marks

One of the children is picked at random.

What is the probability that this child is a girl?

1 mark

What fraction of the girls walk to school?

<hr/>

1 mark

15Complete the table of values for $y = 2x + 3$

x	-2	-1	0	1	2	3
y		1			7	

2 marks

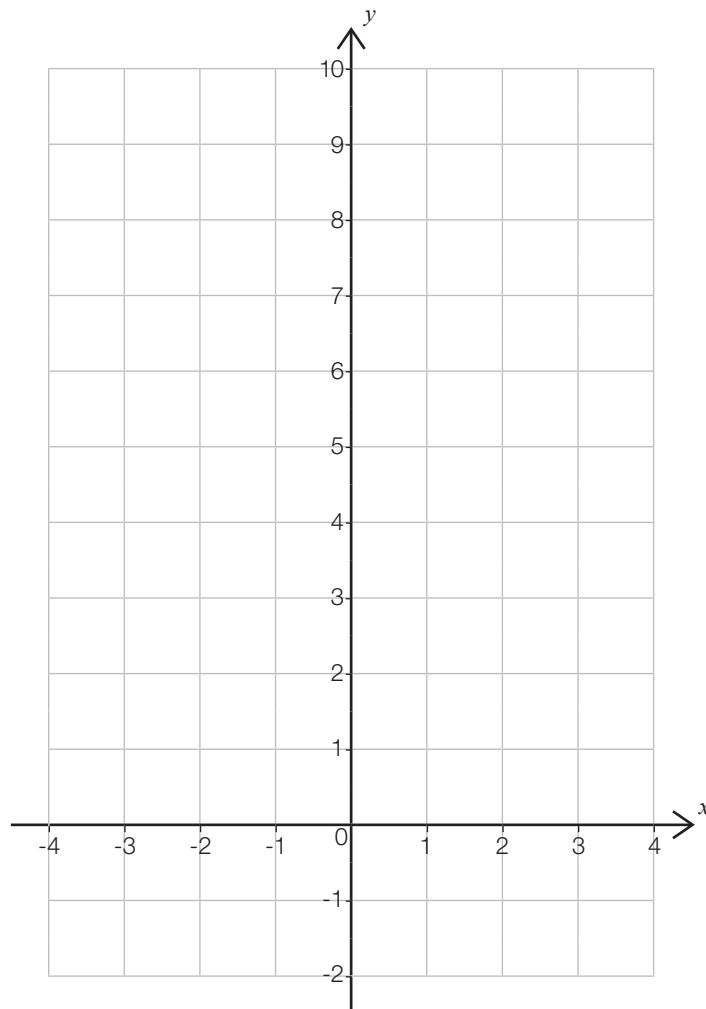
On the grid, draw the graph of $y = 2x + 3$ 

2 marks

16

Here is a Venn diagram.

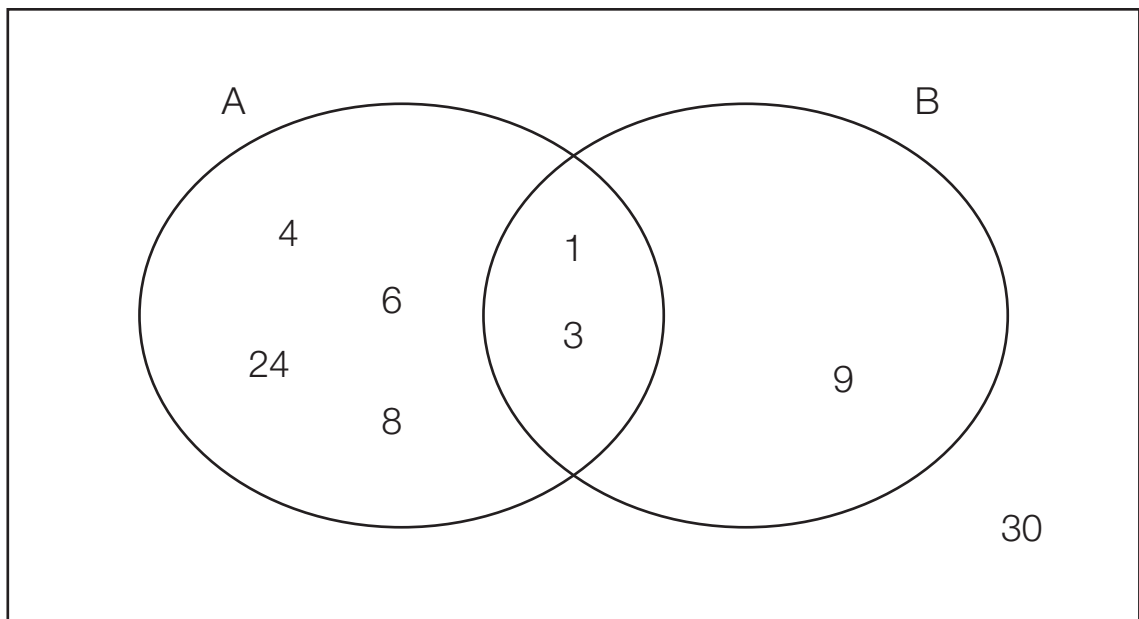

List the members of set B.

1 mark

One number is selected at random from the Venn diagram.

What is the probability this number is a member of set B?

1 mark

END OF TEST

[BLANK PAGE]

Please do not write on this page.

[BLANK PAGE]

Please do not write on this page.

[BLANK PAGE]

Please do not write on this page.